

## LM1815 Adaptive Variable Reluctance Sensor Amplifier

Check for Samples: [LM1815](#)

### FEATURES

- Adaptive Hysteresis
- Single Supply Operation
- Ground Referenced Input
- True Zero Crossing Timing Reference
- Operates from 2V to 12V Supply Voltage
- Handles Inputs from 100 mV<sub>P-P</sub> to over 120V<sub>P-P</sub> with External Resistor
- CMOS Compatible Logic

### APPLICATIONS

- Position Sensing with Notched Wheels
- Zero Crossing Switch
- Motor Speed Control
- Tachometer
- Engine Testing

### DESCRIPTION

The LM1815 is an adaptive sense amplifier and default gating circuit for motor control applications. The sense amplifier provides a one-shot pulse output whose leading edge coincides with the negative-going zero crossing of a ground referenced input signal such as from a variable reluctance magnetic pick-up coil.

In normal operation, this timing reference signal is processed (delayed) externally and returned to the LM1815. A Logic input is then able to select either the timing reference or the processed signal for transmission to the output driver stage.

The adaptive sense amplifier operates with a positive-going threshold which is derived by peak detecting the incoming signal and dividing this down. Thus the input hysteresis varies with input signal amplitude. This enables the circuit to sense in situations where the high speed noise is greater than the low speed signal amplitude. Minimum input signal is 150mV<sub>P-P</sub>.

### Connection Diagram

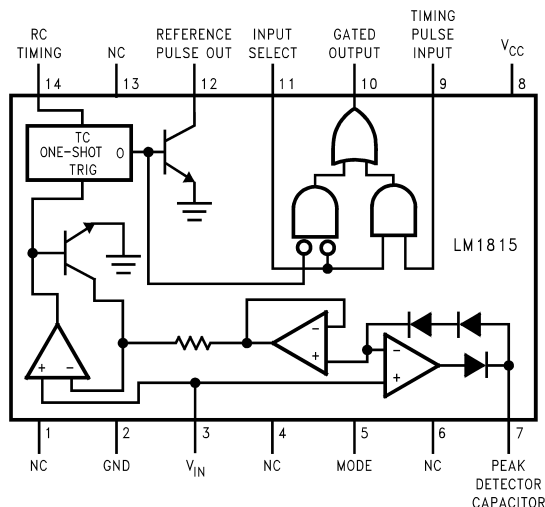

**Figure 1. Top View  
14-Lead SOIC or PDIP  
See D or NFF0014A Package**



These devices have limited built-in ESD protection. The leads should be shorted together or the device placed in conductive foam during storage or handling to prevent electrostatic damage to the MOS gates.



Please be aware that an important notice concerning availability, standard warranty, and use in critical applications of Texas Instruments semiconductor products and disclaimers thereto appears at the end of this data sheet.

All trademarks are the property of their respective owners.

### Absolute Maximum Ratings<sup>(1)(2)</sup>

Supply Voltage	12V
Power Dissipation <sup>(3)</sup>	1250 mW
Operating Temperature Range	-40°C ≤ T <sub>A</sub> ≤ +125°C
Storage Temperature Range	-65°C ≤ T <sub>J</sub> ≤ +150°C
Junction Temperature	+150°C
Input Current	±30 mA
Lead Temperature (Soldering, 10 sec.)	260°C

- (1) "Absolute Maximum Ratings" are those values beyond which the safety of the device cannot be ensured. They are not meant to imply that the devices should be operated at these limits. The table of "Electrical Characteristics" specifies conditions of device operation.
- (2) If Military/Aerospace specified devices are required, please contact the Texas Instruments Sales Office/Distributors for availability and specifications.
- (3) For operation at elevated temperatures, the device must be derated based on a 150°C maximum junction temperature and a thermal resistance of 80°C/W (DIP), 120°C/W (SO-14) junction to ambient.

### Electrical Characteristics

(T<sub>A</sub> = 25°C, V<sub>CC</sub> = 10V, unless otherwise specified, see [Figure 17](#))

Parameter	Conditions	Min	Typ	Max	Units
Operating Supply Voltage		2.5	10	12	V
Supply Current	Pin 3 = -0.1V, Pin 9 = 2V, Pin 11 = 0.8V		3.6	6	mA
Reference Pulse Width	f <sub>IN</sub> = 1Hz to 2kHz, R = 150kΩ, C = 0.001μF	70	100	130	μs
Logic Input Bias Current	V <sub>IN</sub> = 2V, (Pin 9 and Pin 11)			5	μA
Signal Input Bias Current	V <sub>IN</sub> = 0V dc, (Pin 3)		-200		nA
Logic Threshold	(Pin 9 and Pin 11)	0.8	1.1	2.0	V
V <sub>OUT</sub> High	R <sub>L</sub> = 1kΩ, (Pin 10)	7.5	8.6		V
V <sub>OUT</sub> Low	I <sub>SINK</sub> = 0.1mA, (Pin 10)		0.3	0.4	V
Output Leakage Pin 12	V <sub>12</sub> = 11V		0.01	10	μA
Saturation Voltage P12	I <sub>12</sub> = 2mA		0.2	0.4	V
Input Zero Crossing Threshold	All Modes, V <sub>SIGNAL</sub> = 1V pk-pk	-25	0	25	mV <sup>(1)</sup>
Minimum Input Arming Threshold	Mode 1, Pin 5 = Open	30	45	60	mV <sup>(1)</sup>
	Mode 2, Pin 5 = V <sub>CC</sub>	200	300	450	mV <sup>(1)</sup>
	Mode 3, Pin 5 = Gnd	-25	0	25	mV <sup>(1)</sup>
Adaptive Input Arming Threshold	Mode 1, Pin 5 = Open V <sub>SIGNAL</sub> ≥ 230mV pk-pk <sup>(2)</sup>	40	80	90	% <sup>(1)</sup>
	Mode 2, Pin 5 = V <sub>CC</sub> V <sub>SIGNAL</sub> ≥ 1.0V pk-pk <sup>(2)</sup>		80		% <sup>(1)</sup>
	Mode 3, Pin 5 = Gnd V <sub>SIGNAL</sub> ≥ 150mV pk-pk <sup>(2)</sup>		80		% <sup>(1)</sup>

- (1) The Min/Typ Max limits are relative to the positive voltage peak seen at V<sub>IN</sub> Pin 3.
- (2) Tested per [Figure 17](#), V<sub>SIGNAL</sub> is a Sine Wave; F<sub>SIGNAL</sub> is 1000Hz.

### Typical Performance Characteristics

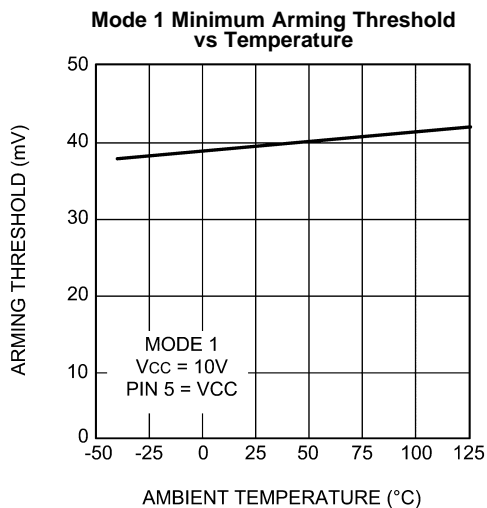

Figure 2.

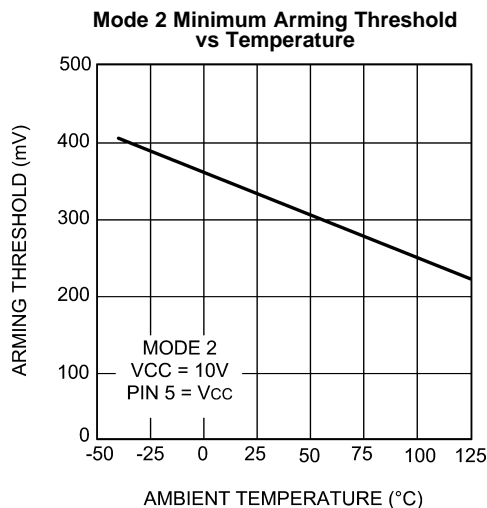

Figure 3.

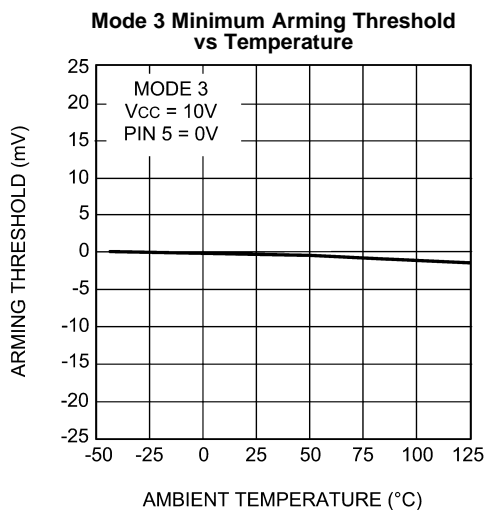

Figure 4.

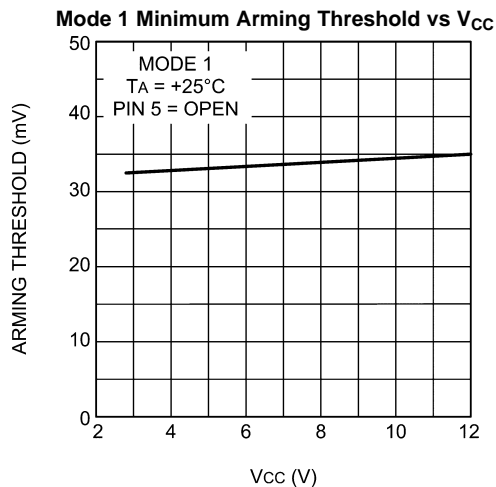

Figure 5.

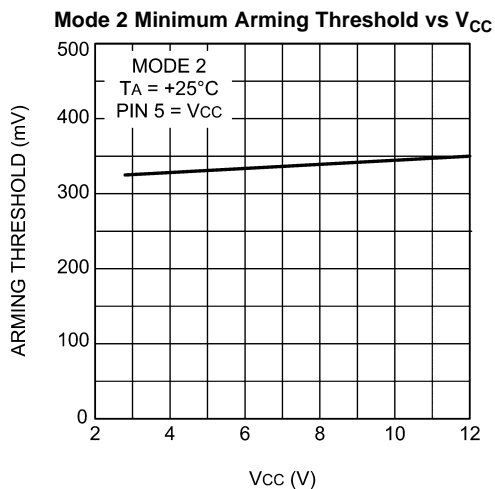

Figure 6.

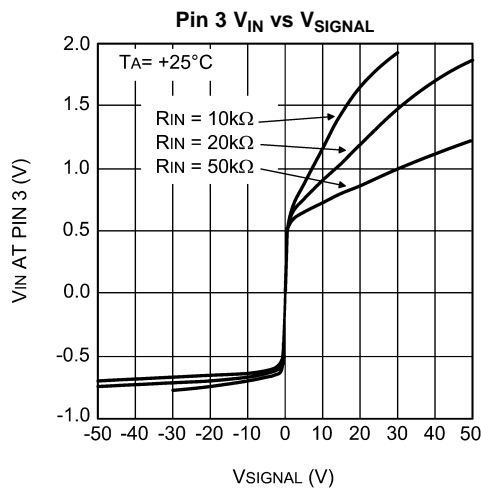

Figure 7.

**Typical Performance Characteristics (continued)**

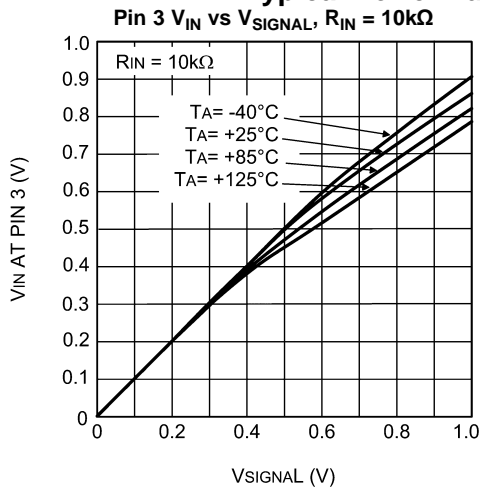

Figure 8.

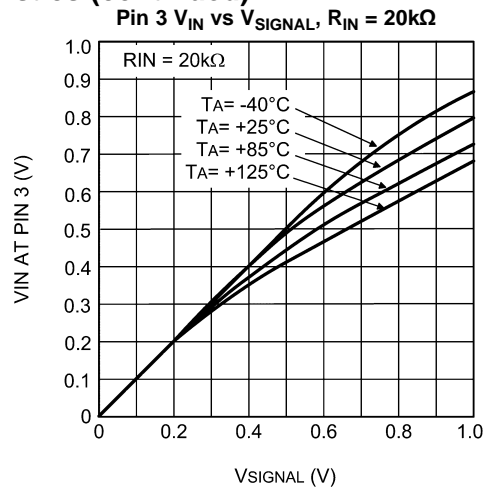

Figure 9.

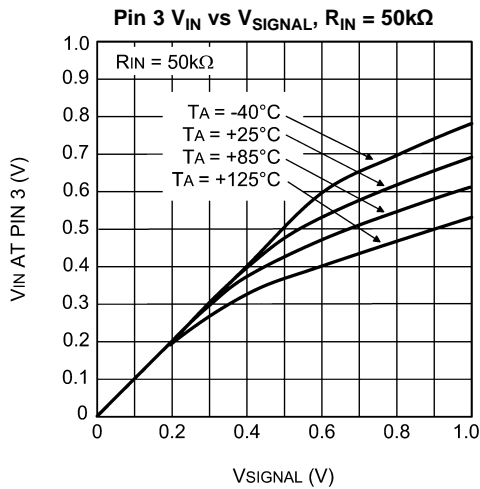

Figure 10.

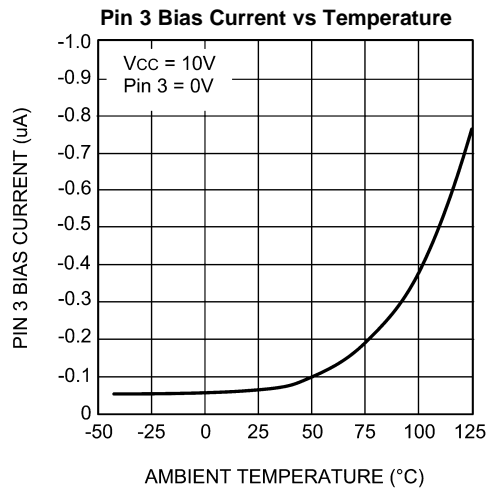

Figure 11.

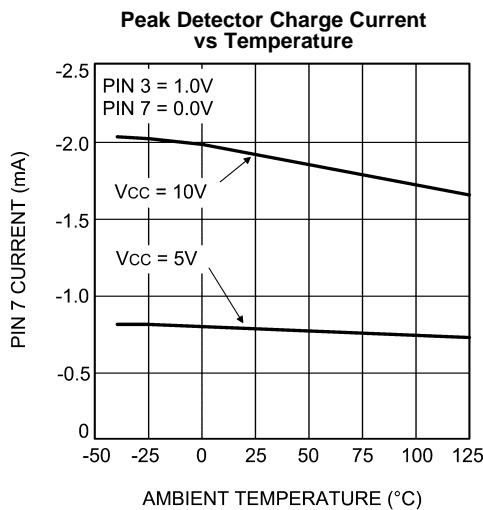

Figure 12.

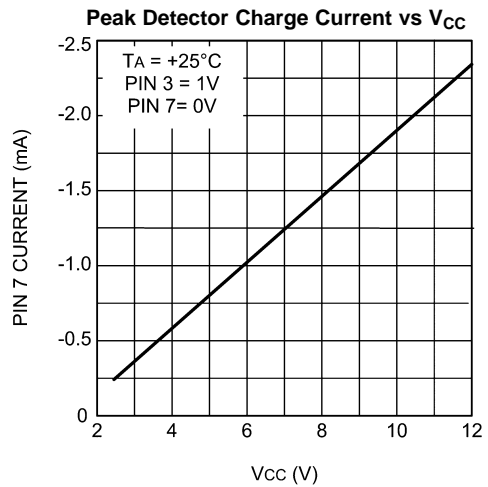

Figure 13.

Typical Performance Characteristics (continued)

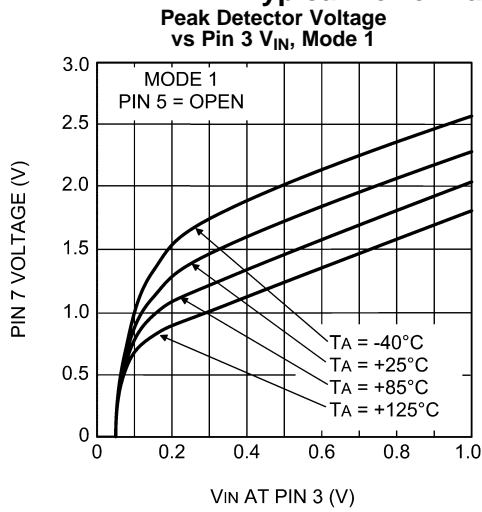

Figure 14.

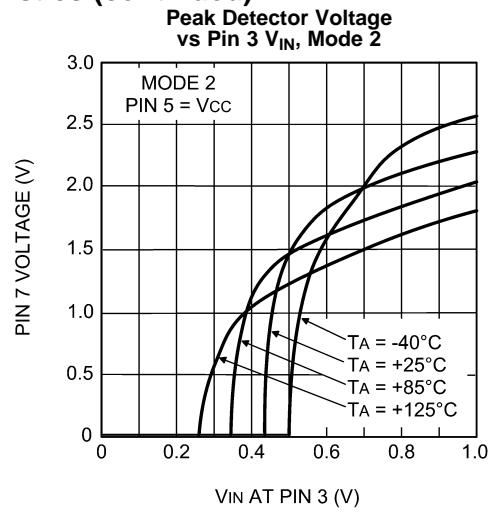

Figure 15.

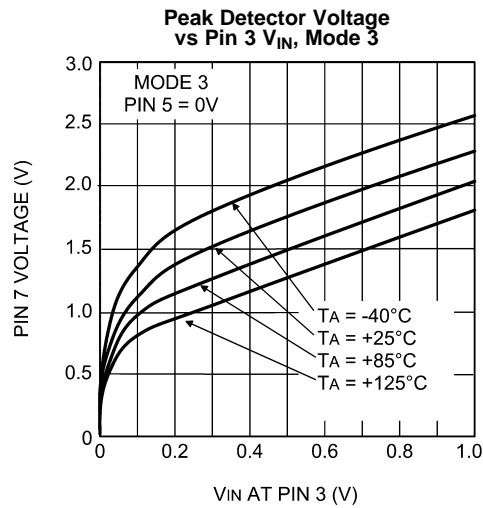

Figure 16.

TRUTH TABLE

Signal Input Pin 3	RC Timing Pin 14	Input Select Pin 11	Timing Input Pin 9	Gated Output Pin 10
± Pulses	RC	L	X	Pulses = RC
X	X	H	H	H
X	X	H	L	L
± Pulses	L	L	L	Zero Crossing

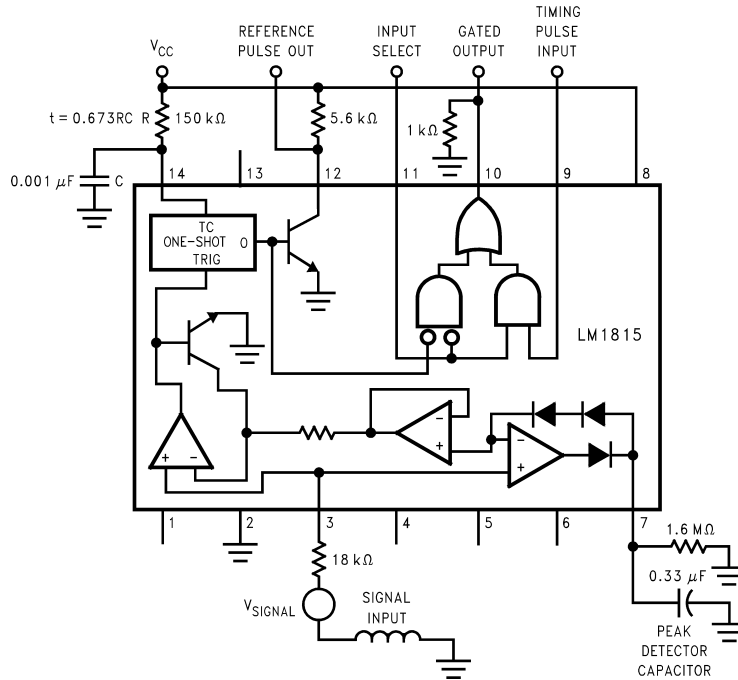
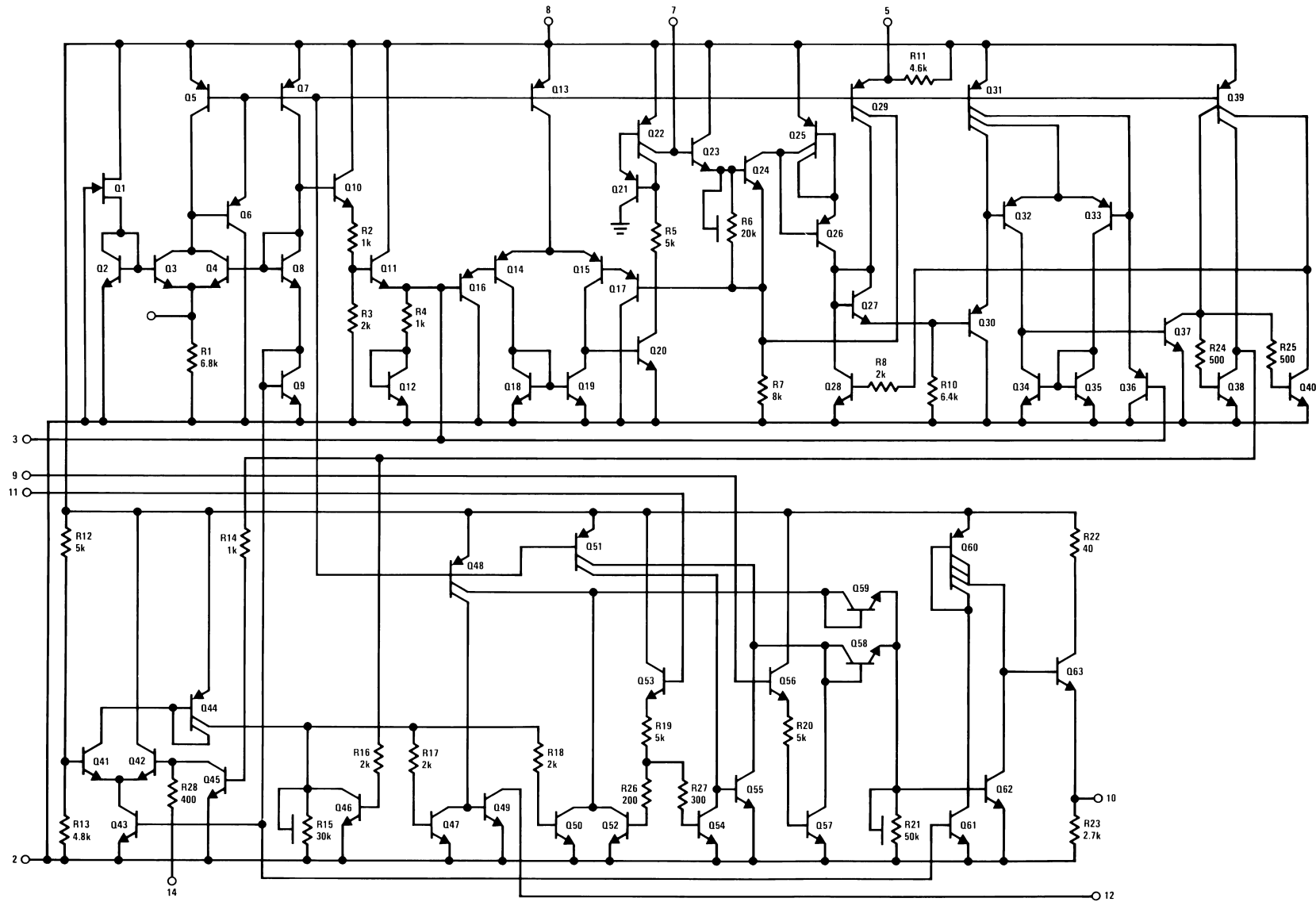

Figure 17. LM1815 Adaptive Sense Amplifier

Schematic Diagram



## APPLICATION HINTS

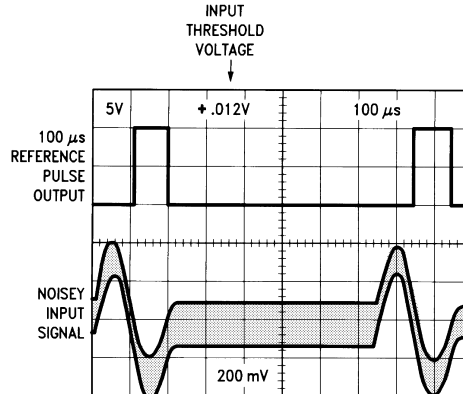

Figure 18. LM1815 Oscilloscopes

### INPUT VOLTAGE CLAMP

The signal input voltage at pin 3 is internally clamped. Current limit for the Input pin is provided by an external resistor which should be selected to allow a peak current of  $\pm 3$  mA in normal operation. Positive inputs are clamped by a  $1\text{k}\Omega$  resistor and series diode (see R4 and Q12 in the internal schematic diagram), while an active clamp limits pin 3 to typically  $350\text{mV}$  below Ground for negative inputs (see R2, R3, Q10, and Q11 in the internal schematic diagram). Thus for input signal transitions that are more than  $350\text{mV}$  below Ground, the input pin current (up to  $3\text{mA}$ ) will be pulled from the  $V+$  supply. If the  $V+$  pin is not adequately bypassed the resulting voltage ripple at the  $V+$  pin will disrupt normal device operation. Likewise, for input signal transitions that are more than  $500\text{mV}$  above Ground, the input pin current will be dumped to Ground through device pin 2. Slight shifts in the Ground potential at device pin 2, due to poor grounding techniques relative to the input signal ground, can cause unreliable operation. As always, adequate device grounding, and  $V+$  bypassing, needs to be considered across the entire input voltage and frequency range for the intended application.

### INPUT CURRENT LIMITING

As stated earlier, current limiting for the Input pin is provided by a user supplied external resistor. For purposes of selecting the appropriate resistor value the Input pin should be considered to be a zero ohm connection to ground. For applications where the input voltage signal is not symmetrical with relationship to Ground the worst case voltage peak should be used.

$$\text{Minimum } R_{\text{ext}} = [(V_{\text{in peak}})/3\text{mA}]$$

In the application example shown in [Figure 17](#) ( $R_{\text{ext}} = 18\text{k}\Omega$ ) the recommended maximum input signal voltage is  $\pm 54\text{V}$  (i.e.  $108\text{Vp-p}$ ).

### OPERATION OF ZERO CROSSING DETECTOR

The LM1815 is designed to operate as a zero crossing detector, triggering an internal one shot on the negative-going edge of the input signal. Unlike other zero crossing detectors, the LM1815 cannot be triggered until the input signal has crossed an "arming" threshold on the positive-going portion of the waveform. The arming circuit is reset when the chip is triggered, and subsequent zero crossings are ignored until the arming threshold is exceeded again. This threshold varies depending on the connection at pin 5. Three different modes of operation are possible:



## MODE 1, PIN 5 OPEN

The adaptive mode is selected by leaving device pin 5 open circuit. For input signals of less than  $\pm 135\text{mV}$  (i.e.  $270\text{ mVp-p}$ ) and greater than typically  $\pm 75\text{mV}$  (i.e.  $150\text{mVp-p}$ ), the input arming threshold is typically at  $45\text{mV}$ . Under these conditions the input signal must first cross the  $45\text{mV}$  threshold in the positive direction to arm the zero crossing detector, and then cross zero in the negative direction to trigger it.

If the signal is less than  $30\text{mV}$  peak (minimum rating in [Electrical Characteristics](#)), the one shot is ensured to not trigger.

Input signals of greater than  $\pm 230\text{mV}$  (i.e.  $460\text{ mVp-p}$ ) will cause the arming threshold to track at 80% of the peak input voltage. A peak detector capacitor at device pin 7 stores a value relative to the positive input peaks to establish the arming threshold. Input signals must exceed this threshold in the positive direction to arm the zero crossing detector, which can then be triggered by a negative-going zero crossing.

The peak detector tracks rapidly as the input signal amplitude increases, and decays by virtue of the resistor connected externally at pin 7 track decreases in the input signal.

If the input signal amplitude falls faster than the voltage stored on the peak detector capacitor there may be a loss of output signal until the capacitor voltage has decayed to an appropriate level.

Note that since the input voltage is clamped, the waveform observed at pin 3 is not identical to the waveform observed at the variable reluctance sensor. Similarly, the voltage stored at pin 7 is not identical to the peak voltage appearing at pin 3.

## MODE 2, PIN 5 CONNECTED TO V+

The input arming threshold is fixed at  $200\text{mV}$  minimum when device pin 5 is connected to the positive supply. The chip has no output for signals of less than  $\pm 200\text{ mV}$  (i.e.  $400\text{mVp-p}$ ) and triggers on the next negative-going zero crossing when the arming threshold is has been exceeded.

## MODE 3, PIN 5 GROUNDED

With pin 5 grounded, the input arming threshold is set to  $0\text{V}$ ,  $\pm 25\text{mV}$  maximum. Positive-going zero crossings arm the chip, and the next negative-going zero crossing triggers it. This is the very basic form of zero-crossing detection.

## ONE SHOT TIMING

The one shot timing is set by a resistor and capacitor connected to pin 14. The recommended maximum resistor value is  $150\text{kohms}$ . The capacitor value can be changed as needed, as long as the capacitor type does not present any significant leakage that would adversely affect the RC time constant.

The output pulse width is:

$$\text{pulse width} = 0.673 \times R \times C \quad (1)$$

For a given One Shot pulse width, the recommended maximum input signal frequency is:

$$F_{in(\text{max})} = 1/(1.346 \times R \times C) \quad (2)$$

In the application example shown in [Figure 17](#) ( $R=150\text{kohms}$ ,  $C=0.001\mu\text{F}$ ) the recommended maximum input frequency will typically be  $5\text{kHz}$ . Operating with input frequencies above the recommended  $F_{in(\text{max})}$  value may result in unreliable performance of the One Shot circuitry. For those applications where the One Shot circuit is not required, device pin 14 can be tied directly to Ground.

## LOGIC INPUTS

In some systems it is necessary to externally generate pulses, such as during stall conditions when the variable reluctance sensor has no output. External pulse inputs at pin 9 are gated through to pin 10 when Input Select (pin 11) is pulled high. Pin 12 is a direct output for the one shot and is unaffected by the status of pin 11.

Input/output pins 9, 11, 10, and 12 are all CMOS logic compatible. In addition, pins 9, 11, and 12 are TTL compatible. Pin 10 is not ensured to drive a TTL load.

Pins 1, 4, 6 and 13 have no internal connections and can be grounded.

## REVISION HISTORY

Changes from Revision E (March 2013) to Revision F	Page
• Changed layout of National Data Sheet to TI format .....	<a href="#">9</a>

**PACKAGING INFORMATION**

Orderable Device	Status (1)	Package Type	Package Drawing	Pins	Package Qty	Eco Plan (2)	Lead/Ball Finish (6)	MSL Peak Temp (3)	Op Temp (°C)	Device Marking (4/5)	Samples
LM1815M/NOPB	ACTIVE	SOIC	D	14	55	Green (RoHS & no Sb/Br)	CU SN	Level-1-260C-UNLIM	-40 to 125	LM1815M	<a href="#">Samples</a>
LM1815MX/NOPB	ACTIVE	SOIC	D	14	2500	Green (RoHS & no Sb/Br)	CU SN	Level-1-260C-UNLIM	-40 to 125	LM1815M	<a href="#">Samples</a>
LM1815N/NOPB	ACTIVE	PDIP	NFF	14	25	Green (RoHS & no Sb/Br)	CU SN	Level-1-NA-UNLIM	-40 to 125	LM1815N	<a href="#">Samples</a>

(1) The marketing status values are defined as follows:

**ACTIVE:** Product device recommended for new designs.

**LIFEBUY:** TI has announced that the device will be discontinued, and a lifetime-buy period is in effect.

**NRND:** Not recommended for new designs. Device is in production to support existing customers, but TI does not recommend using this part in a new design.

**PREVIEW:** Device has been announced but is not in production. Samples may or may not be available.

**OBsolete:** TI has discontinued the production of the device.

(2) **RoHS:** TI defines "RoHS" to mean semiconductor products that are compliant with the current EU RoHS requirements for all 10 RoHS substances, including the requirement that RoHS substance do not exceed 0.1% by weight in homogeneous materials. Where designed to be soldered at high temperatures, "RoHS" products are suitable for use in specified lead-free processes. TI may reference these types of products as "Pb-Free".

**RoHS Exempt:** TI defines "RoHS Exempt" to mean products that contain lead but are compliant with EU RoHS pursuant to a specific EU RoHS exemption.

**Green:** TI defines "Green" to mean the content of Chlorine (Cl) and Bromine (Br) based flame retardants meet JS709B low halogen requirements of <=1000ppm threshold. Antimony trioxide based flame retardants must also meet the <=1000ppm threshold requirement.

(3) MSL, Peak Temp. - The Moisture Sensitivity Level rating according to the JEDEC industry standard classifications, and peak solder temperature.

(4) There may be additional marking, which relates to the logo, the lot trace code information, or the environmental category on the device.

(5) Multiple Device Markings will be inside parentheses. Only one Device Marking contained in parentheses and separated by a "-" will appear on a device. If a line is indented then it is a continuation of the previous line and the two combined represent the entire Device Marking for that device.

(6) Lead/Ball Finish - Orderable Devices may have multiple material finish options. Finish options are separated by a vertical ruled line. Lead/Ball Finish values may wrap to two lines if the finish value exceeds the maximum column width.

**Important Information and Disclaimer:** The information provided on this page represents TI's knowledge and belief as of the date that it is provided. TI bases its knowledge and belief on information provided by third parties, and makes no representation or warranty as to the accuracy of such information. Efforts are underway to better integrate information from third parties. TI has taken and continues to take reasonable steps to provide representative and accurate information but may not have conducted destructive testing or chemical analysis on incoming materials and chemicals. TI and TI suppliers consider certain information to be proprietary, and thus CAS numbers and other limited information may not be available for release.

In no event shall TI's liability arising out of such information exceed the total purchase price of the TI part(s) at issue in this document sold by TI to Customer on an annual basis.

## TAPE AND REEL INFORMATION



### QUADRANT ASSIGNMENTS FOR PIN 1 ORIENTATION IN TAPE



\*All dimensions are nominal

Device	Package Type	Package Drawing	Pins	SPQ	Reel Diameter (mm)	Reel Width W1 (mm)	A0 (mm)	B0 (mm)	K0 (mm)	P1 (mm)	W (mm)	Pin1 Quadrant
LM1815MX/NOPB	SOIC	D	14	2500	330.0	16.4	6.5	9.35	2.3	8.0	16.0	Q1

TAPE AND REEL BOX DIMENSIONS



\*All dimensions are nominal

Device	Package Type	Package Drawing	Pins	SPQ	Length (mm)	Width (mm)	Height (mm)
LM1815MX/NOPB	SOIC	D	14	2500	367.0	367.0	35.0

D (R-PDSO-G14)

PLASTIC SMALL OUTLINE

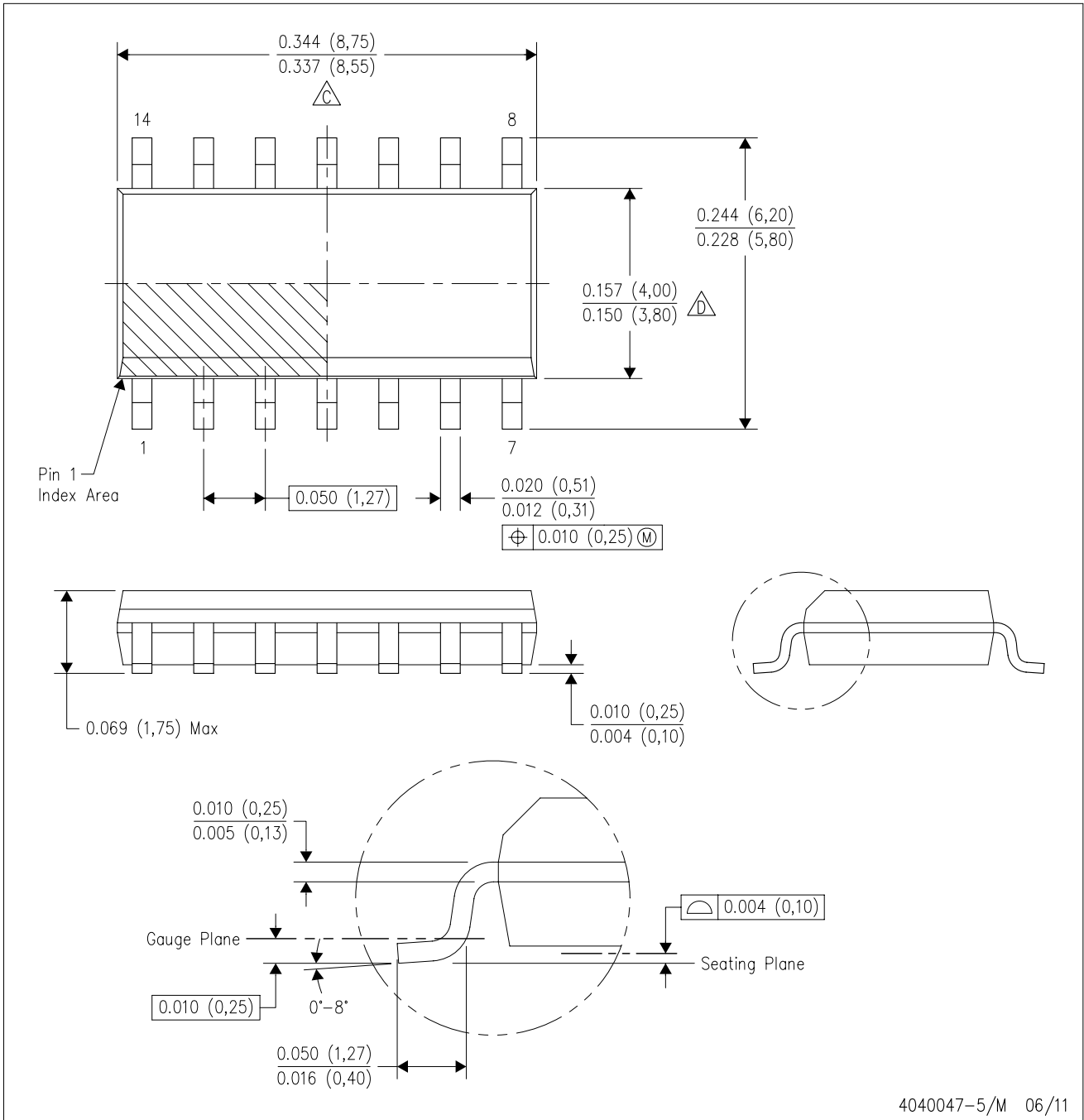

4040047-5/M 06/11

NFF0014A

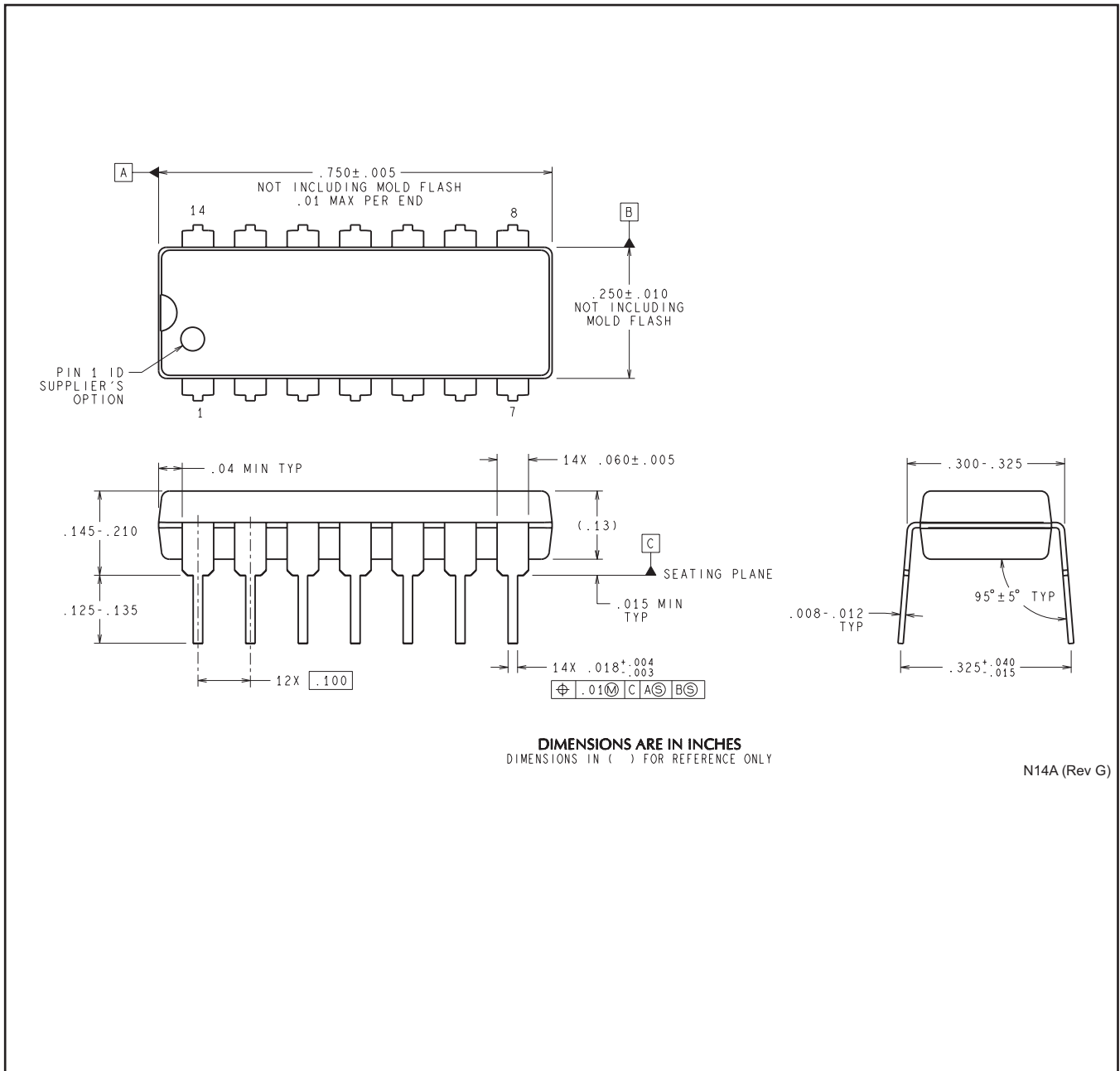

**DIMENSIONS ARE IN INCHES**  
 DIMENSIONS IN ( ) FOR REFERENCE ONLY

N14A (Rev G)



## IMPORTANT NOTICE

Texas Instruments Incorporated (TI) reserves the right to make corrections, enhancements, improvements and other changes to its semiconductor products and services per JESD46, latest issue, and to discontinue any product or service per JESD48, latest issue. Buyers should obtain the latest relevant information before placing orders and should verify that such information is current and complete.

TI's published terms of sale for semiconductor products (<http://www.ti.com/sc/docs/stdterms.htm>) apply to the sale of packaged integrated circuit products that TI has qualified and released to market. Additional terms may apply to the use or sale of other types of TI products and services.

Reproduction of significant portions of TI information in TI data sheets is permissible only if reproduction is without alteration and is accompanied by all associated warranties, conditions, limitations, and notices. TI is not responsible or liable for such reproduced documentation. Information of third parties may be subject to additional restrictions. Resale of TI products or services with statements different from or beyond the parameters stated by TI for that product or service voids all express and any implied warranties for the associated TI product or service and is an unfair and deceptive business practice. TI is not responsible or liable for any such statements.

Buyers and others who are developing systems that incorporate TI products (collectively, "Designers") understand and agree that Designers remain responsible for using their independent analysis, evaluation and judgment in designing their applications and that Designers have full and exclusive responsibility to assure the safety of Designers' applications and compliance of their applications (and of all TI products used in or for Designers' applications) with all applicable regulations, laws and other applicable requirements. Designer represents that, with respect to their applications, Designer has all the necessary expertise to create and implement safeguards that (1) anticipate dangerous consequences of failures, (2) monitor failures and their consequences, and (3) lessen the likelihood of failures that might cause harm and take appropriate actions. Designer agrees that prior to using or distributing any applications that include TI products, Designer will thoroughly test such applications and the functionality of such TI products as used in such applications.

TI's provision of technical, application or other design advice, quality characterization, reliability data or other services or information, including, but not limited to, reference designs and materials relating to evaluation modules, (collectively, "TI Resources") are intended to assist designers who are developing applications that incorporate TI products; by downloading, accessing or using TI Resources in any way, Designer (individually or, if Designer is acting on behalf of a company, Designer's company) agrees to use any particular TI Resource solely for this purpose and subject to the terms of this Notice.

TI's provision of TI Resources does not expand or otherwise alter TI's applicable published warranties or warranty disclaimers for TI products, and no additional obligations or liabilities arise from TI providing such TI Resources. TI reserves the right to make corrections, enhancements, improvements and other changes to its TI Resources. TI has not conducted any testing other than that specifically described in the published documentation for a particular TI Resource.

Designer is authorized to use, copy and modify any individual TI Resource only in connection with the development of applications that include the TI product(s) identified in such TI Resource. NO OTHER LICENSE, EXPRESS OR IMPLIED, BY ESTOPPEL OR OTHERWISE TO ANY OTHER TI INTELLECTUAL PROPERTY RIGHT, AND NO LICENSE TO ANY TECHNOLOGY OR INTELLECTUAL PROPERTY RIGHT OF TI OR ANY THIRD PARTY IS GRANTED HEREIN, including but not limited to any patent right, copyright, mask work right, or other intellectual property right relating to any combination, machine, or process in which TI products or services are used. Information regarding or referencing third-party products or services does not constitute a license to use such products or services, or a warranty or endorsement thereof. Use of TI Resources may require a license from a third party under the patents or other intellectual property of the third party, or a license from TI under the patents or other intellectual property of TI.

TI RESOURCES ARE PROVIDED "AS IS" AND WITH ALL FAULTS. TI DISCLAIMS ALL OTHER WARRANTIES OR REPRESENTATIONS, EXPRESS OR IMPLIED, REGARDING RESOURCES OR USE THEREOF, INCLUDING BUT NOT LIMITED TO ACCURACY OR COMPLETENESS, TITLE, ANY EPIDEMIC FAILURE WARRANTY AND ANY IMPLIED WARRANTIES OF MERCHANTABILITY, FITNESS FOR A PARTICULAR PURPOSE, AND NON-INFRINGEMENT OF ANY THIRD PARTY INTELLECTUAL PROPERTY RIGHTS. TI SHALL NOT BE LIABLE FOR AND SHALL NOT DEFEND OR INDEMNIFY DESIGNER AGAINST ANY CLAIM, INCLUDING BUT NOT LIMITED TO ANY INFRINGEMENT CLAIM THAT RELATES TO OR IS BASED ON ANY COMBINATION OF PRODUCTS EVEN IF DESCRIBED IN TI RESOURCES OR OTHERWISE. IN NO EVENT SHALL TI BE LIABLE FOR ANY ACTUAL, DIRECT, SPECIAL, COLLATERAL, INDIRECT, PUNITIVE, INCIDENTAL, CONSEQUENTIAL OR EXEMPLARY DAMAGES IN CONNECTION WITH OR ARISING OUT OF TI RESOURCES OR USE THEREOF, AND REGARDLESS OF WHETHER TI HAS BEEN ADVISED OF THE POSSIBILITY OF SUCH DAMAGES.

Unless TI has explicitly designated an individual product as meeting the requirements of a particular industry standard (e.g., ISO/TS 16949 and ISO 26262), TI is not responsible for any failure to meet such industry standard requirements.

Where TI specifically promotes products as facilitating functional safety or as compliant with industry functional safety standards, such products are intended to help enable customers to design and create their own applications that meet applicable functional safety standards and requirements. Using products in an application does not by itself establish any safety features in the application. Designers must ensure compliance with safety-related requirements and standards applicable to their applications. Designer may not use any TI products in life-critical medical equipment unless authorized officers of the parties have executed a special contract specifically governing such use. Life-critical medical equipment is medical equipment where failure of such equipment would cause serious bodily injury or death (e.g., life support, pacemakers, defibrillators, heart pumps, neurostimulators, and implantables). Such equipment includes, without limitation, all medical devices identified by the U.S. Food and Drug Administration as Class III devices and equivalent classifications outside the U.S.

TI may expressly designate certain products as completing a particular qualification (e.g., Q100, Military Grade, or Enhanced Product). Designers agree that it has the necessary expertise to select the product with the appropriate qualification designation for their applications and that proper product selection is at Designers' own risk. Designers are solely responsible for compliance with all legal and regulatory requirements in connection with such selection.

Designer will fully indemnify TI and its representatives against any damages, costs, losses, and/or liabilities arising out of Designer's non-compliance with the terms and provisions of this Notice.