

LM26 SOT-23, $\pm 3^{\circ}\text{C}$ Accurate, Factory-Preset Thermostat

1 Features

- Internal Comparator With Pin Programmable 2°C or 10°C Hysteresis
- No External Components Required
- Open-Drain or Push-Pull Digital Output; Supports CMOS Logic Levels
- Internal Temperature Sensor With V_{TEMP} Output Pin
- V_{TEMP} Output Allows After-Assembly System Testing
- Internal Voltage Reference and DAC for Trip-Point Setting
- Currently Available in 5-pin SOT-23 Plastic Package
- Excellent Power Supply Noise Rejection
- UL Recognized Component 
- Key Specifications
 - Power Supply Voltage 2.7 V to 5.5 V
 - Power Supply Current
40 μA (Maximum) 16 μA (Typical)
 - Hysteresis Temperature 2°C or 10°C (Typical)

2 Applications

- Microprocessor Thermal Management
- Appliances
- Portable Battery Powered Systems
- Fan Control
- Industrial Process Control
- HVAC Systems
- Remote Temperature Sensing
- Electronic System Protection

3 Description

The LM26 is a precision, single digital-output, low-power thermostat comprised of an internal reference, DAC, temperature sensor and comparator. Utilizing factory programming, it can be manufactured with different trip points as well as different digital output functionality. The trip point (T_{OS}) can be preset at the factory to any temperature in the range of -55°C to 110°C in 1°C increments. The LM26 has one digital output ($\text{OS}/\overline{\text{OS}}/\text{US}/\overline{\text{US}}$), one digital input (HYST) and one analog output (V_{TEMP}). The digital output stage can be preset as either open-drain or push-pull. In addition, it can be factory programmed to be active HIGH or LOW. The digital output can be factory programmed to indicate an over temperature shutdown event (OS or $\overline{\text{OS}}$) or an under temperature shutdown event (US or $\overline{\text{US}}$). When preset as an overtemperature shutdown ($\overline{\text{OS}}$) it will go LOW to indicate that the die temperature is over the internally preset T_{OS} and go HIGH when the temperature goes below ($T_{\text{OS}} - T_{\text{HYST}}$). Similarly, when preprogrammed as an undertemperature shutdown (US) it will go HIGH to indicate that the temperature is below T_{US} and go LOW when the temperature is above ($T_{\text{US}} + T_{\text{HYST}}$). The typical hysteresis, T_{HYST} , can be set to 2°C or 10°C and is controlled by the state of the HYST pin. A V_{TEMP} analog output provides a voltage that is proportional to temperature and has a -10.82 mV/ $^{\circ}\text{C}$ output slope.

Available parts are detailed in the [Device Comparison Table](#). For other part options, contact a Texas Instruments Distributor or Sales Representative for information on minimum order qualification. The LM26 is currently available in a 5-lead SOT-23 package.

Device Information⁽¹⁾

PART NUMBER	PACKAGE	BODY SIZE (NOM)
LM26	SOT-23 (5)	2.90 mm x 1.60 mm

(1) For all available packages, see the orderable addendum at the end of the datasheet.

LM26CIM5-TPA Simplified Block Diagram and Connection Diagram

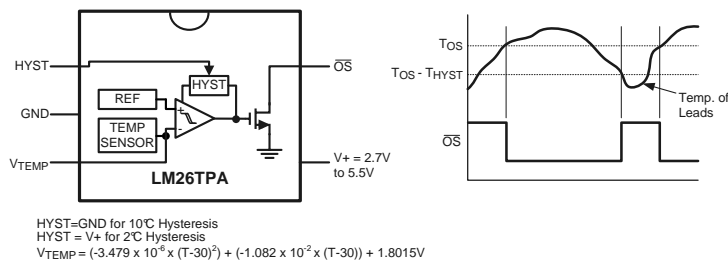

The LM26CIM5-TPA has a fixed trip point of 85°C . For other trip point and output function availability, please see the [Device Comparison Table](#) or contact Texas Instruments.



Table of Contents

1 Features 1 2 Applications 1 3 Description 1 4 Revision History 2 5 Device Comparison Table 3 6 Pin Configuration and Functions 4 7 Specifications 4 7.1 Absolute Maximum Ratings 4 7.2 ESD Ratings..... 5 7.3 Recommended Operating Conditions 5 7.4 Thermal Information 5 7.5 Electrical Characteristics 5 7.6 Typical Characteristics 6 8 Detailed Description 7 8.1 Overview 7 8.2 Functional Block Diagrams 7 8.3 Feature Description..... 8	8.4 Device Functional Modes..... 9 9 Application and Implementation 10 9.1 Application Information..... 10 9.2 Typical Application 10 9.3 System Examples 11 10 Power Supply Recommendations 12 11 Layout 12 11.1 Layout Guidelines 12 11.2 Layout Example 12 11.3 Thermal Considerations 13 11.4 Part Number Template..... 14 12 Device and Documentation Support 15 12.1 Community Resources..... 15 12.2 Trademarks 15 12.3 Electrostatic Discharge Caution..... 15 12.4 Glossary 15 13 Mechanical, Packaging, and Orderable Information 15
--	---

4 Revision History

NOTE: Page numbers for previous revisions may differ from page numbers in the current version.

Changes from Revision R (February 2013) to Revision S	Page
<ul style="list-style-type: none"> • Added <i>Pin Configuration and Functions</i> section, <i>Handling Rating</i> table, <i>Feature Description</i> section, <i>Device Functional Modes</i>, <i>Application and Implementation</i> section, <i>Power Supply Recommendations</i> section, <i>Layout</i> section, <i>Device and Documentation Support</i> section, and <i>Mechanical, Packaging, and Orderable Information</i> section 1 • Removed <i>Part Number Template</i> table 6 • Removed <i>Temperature Trip Point Accuracy</i> table 6 	
Changes from Revision Q (September 2011) to Revision R	Page
<ul style="list-style-type: none"> • Changed layout of National Data Sheet to TI format 11 	

5 Device Comparison Table

Order Number		Top Mark	Trip Point Setting	Output Function
Bulk Rail (1000 Units)	Tape & Reel (3000 Units)			
LM26CIM5-BPB	LM26CIM5X-BPB	TBPB	-45°C	Active-Low, Open-Drain, \overline{US} output
LM26CIM5-DPB	LM26CIM5X-DPB	TDPB	-25°C	Active-Low, Open-Drain, \overline{US} output
LM26CIM5-HHD	LM26CIM5X-HHD	THHD	0°C	Active-High, Push-Pull, US output
LM26CIM5-NPA	LM26CIM5X-NPA	TNPA	45°C	Active-Low, Open-Drain, \overline{OS} output
LM26CIM5-RPA	LM26CIM5X-RPA	TRPA	65°C	Active-Low, Open-Drain, \overline{OS} output
LM26CIM5-SHA	LM26CIM5X-SHA	TSHA	75°C	Active-Low, Open-Drain, \overline{OS} output
LM26CIM5-SPA	LM26CIM5X-SPA	TSPA	70°C	Active-Low, Open-Drain, \overline{OS} output
LM26CIM5-TPA	LM26CIM5X-TPA	TTPA	85°C	Active-Low, Open-Drain, \overline{OS} output
LM26CIM5-VHA	LM26CIM5X-VHA	TVHA	90°C	Active-Low, Open-Drain, \overline{OS} output
LM26CIM5-VPA	LM26CIM5X-VPA	TVPA	95°C	Active-Low, Open-Drain, \overline{OS} output
LM26CIM5-XHA	LM26CIM5X-XHA	TXHA	100°C	Active-Low, Open-Drain, \overline{OS} output
LM26CIM5-XPA	LM26CIM5X-XPA	TXPA	105°C	Active-Low, Open-Drain, \overline{OS} output
LM26CIM5-YHA	LM26CIM5X-YHA	TYHA	110°C	Active-Low, Open-Drain, \overline{OS} output
LM26CIM5-YPA	LM26CIM5X-YPA	TYPA	115°C	Active-Low, Open-Drain, \overline{OS} output
LM26CIM5-ZHA	LM26CIM5X-ZHA	TZHA	120°C	Active-Low, Open-Drain, \overline{OS} output

6 Pin Configuration and Functions

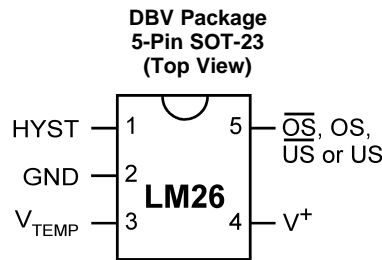

Pin Functions

PIN		TYPE	DESCRIPTION
NO.	NAME		
1	HYST	Input	Hysteresis control, digital input; connect to GND for 10°C or V+ for 2°C
2	GND	Power	Ground, connected to the back side of the die through lead frame; connect to system ground
3	V _{TEMP}	Output	Analog output voltage proportional to temperature; leave floating or connect to a high impedance node.
4	V ⁺	Power	Supply input; connect to 2.7 V to 5.5 V with a 0.1-μF bypass capacitor.
5 ⁽¹⁾	OS-bar	Output	Overtemperature Shutdown open-drain active low thermostat digital output; connect to controller interrupt, system/power supply shutdown; pullup resistor ≥ 10 kΩ
	OS	Output	Overtemperature Shutdown push-pull active high thermostat digital output; connect to controller interrupt, system/power supply shutdown
	US-bar	Output	Undertemperature Shutdown open-drain active low thermostat digital output; connect to controller interrupt, system/power supply shutdown; pullup resistor ≥ 10 kΩ
	US	Output	Undertemperature Shutdown push-pull active high thermostat digital output; connect to controller interrupt, system/power supply shutdown

(1) Pin 5 functionality and trip point setting are programmed during LM26 manufacture.

7 Specifications

7.1 Absolute Maximum Ratings

over operating free-air temperature range (unless otherwise noted) ⁽¹⁾

		MIN	MAX	UNIT
Input Voltage			6	V
Input Current at any pin ⁽²⁾			5	mA
Package Input Current ⁽²⁾			20	mA
Package Dissipation at T _A = 25°C ⁽³⁾			500	mW
Soldering Information ⁽⁴⁾	SOT-23 Package	Vapor Phase (60 seconds)		°C
		Infrared (15 seconds)		
Storage Temperature, T _{stg}		-65	150	°C

- (1) Stresses beyond those listed under *Absolute Maximum Ratings* may cause permanent damage to the device. These are stress ratings only, which do not imply functional operation of the device at these or any other conditions beyond those indicated under *Recommended Operating Conditions*. Exposure to absolute-maximum-rated conditions for extended periods may affect device reliability.
- (2) When the input voltage (V_I) at any pin exceeds the power supply (V_I < GND or V_I > V⁺), the current at that pin should be limited to 5 mA. The 20-mA maximum package input current rating limits the number of pins that can safely exceed the power supplies with an input current of 5 mA to four. Under normal operating conditions the maximum current that pins 2, 4 or 5 can handle is limited to 5 mA each.
- (3) The maximum power dissipation must be derated at elevated temperatures and is dictated by T_{JMAX} (maximum junction temperature), θ_{JA} (junction to ambient thermal resistance) and T_A (ambient temperature). The maximum allowable power dissipation at any temperature is P_D = (T_{JMAX} - T_A) / θ_{JA} or the number given in the *Absolute Maximum Ratings*, whichever is lower. For this device, T_{JMAX} = 150°C. For this device the typical thermal resistance (θ_{JA}) of the different package types when board mounted follow:
- (4) See the URL <http://www.ti.com/packaging> for other recommendations and methods of soldering surface mount devices.

7.2 ESD Ratings

		VALUE	UNIT
V _(ESD)	Electrostatic discharge ⁽¹⁾	Human body model (HBM)	±2500
		Machine Model	±250
			V

(1) The human body model is a 100-pF capacitor discharge through a 1.5-kΩ resistor into each pin. The machine model is a 200-pF capacitor discharged directly into each pin.

7.3 Recommended Operating Conditions

over operating free-air temperature range (unless otherwise noted)⁽¹⁾

	MIN	MAX	UNIT
Specified Temperature Range (T _{MIN} ≤ T _A ≤ T _{MAX})	-55	125	°C
Positive Supply Voltage (V ⁺)	2.7	5.5	V
Maximum V _{OUT}		5.5	V

(1) *Absolute Maximum Ratings* indicate limits beyond which damage to the device may occur. *Operating Ratings* indicate conditions for which the device is functional, but do not guarantee specific performance limits. For guaranteed specifications and test conditions, see the *Electrical Characteristics*. The guaranteed specifications apply only for the test conditions listed. Some performance characteristics may degrade when the device is not operated under the listed test conditions.

7.4 Thermal Information

THERMAL METRIC ⁽¹⁾	LM26	UNIT
	DBV (SOT-23)	
	5 PINS	
R _{θJA} Junction-to-ambient thermal resistance	250	°C/W

(1) For more information about traditional and new thermal metrics, see the *Semiconductor and IC Package Thermal Metrics* application report, [SPRA953](#).

7.5 Electrical Characteristics

The following specifications apply for V⁺ = 2.7 V_{DC} to 5.5 V_{DC}, and V_{TEMP} load current = 0 μA unless otherwise specified. All limits apply for T_A = T_J = T_{MIN} to T_{MAX} unless otherwise specified.

PARAMETER	TEST CONDITIONS	MIN ⁽¹⁾	TYP ⁽²⁾	MAX ⁽¹⁾	UNIT
TEMPERATURE SENSOR					
Trip Point Accuracy (Includes V _{REF} , DAC, Comparator Offset, and Temperature Sensitivity errors)	-55°C ≤ T _A ≤ +110°C			±3	°C
	T _A = +120°C			±4	°C
Trip Point Hysteresis	HYST = GND		11		°C
	HYST = V ⁺		2		°C
V _{TEMP} Output Temperature Sensitivity			-10.82		mV/°C
V _{TEMP} Temperature Sensitivity Error to Equation: V _O = (-3.479 × 10 ⁻⁶ × (T - 30) ²) + (-1.082 × 10 ⁻² × (T - 30)) + 1.8015 V	-30°C ≤ T _A ≤ 120°C			±3	°C
	-55°C ≤ T _A ≤ 120°C, 4.5 V ≤ V ⁺ ≤ 5.5 V			±3	°C
	T _A = 30°C			±2.5	°C
V _{TEMP} Load Regulation	Source ≤ 1 μA		0.070		mV
	Sink ≤ 40 μA			0.7	mV
V _{TEMP} Line Regulation	+2.7 V ≤ V ⁺ ≤ +5.5 V, -30°C ≤ T _A ≤ +120°C		-0.2		mV/V
I _S Supply Current	T _A = 25°C		16	20	μA
				40	

(1) Limits are guaranteed to TI's AOQL (Average Outgoing Quality Level).

(2) Typicals are at T_J = T_A = 25°C and represent most likely parametric norm.

Electrical Characteristics (continued)

The following specifications apply for $V^+ = 2.7 V_{DC}$ to $5.5 V_{DC}$, and V_{TEMP} load current = $0 \mu A$ unless otherwise specified. All limits apply for $T_A = T_J = T_{MIN}$ to T_{MAX} unless otherwise specified.

PARAMETER		TEST CONDITIONS		MIN ⁽¹⁾	TYP ⁽²⁾	MAX ⁽¹⁾	UNIT
DIGITAL OUTPUT AND INPUT							
$I_{OUT(1)}$	Logical 1 Output Leakage Current ⁽³⁾	$T_A = 25^\circ C$	$V^+ = +5.0 V$		0.001	1	μA
$V_{OUT(0)}$	Logical 0 Output Voltage	$I_{OUT} = +1.2 mA$ and $V^+ \geq 2.7 V$; $I_{OUT} = +3.2 mA$ and $V^+ \geq 4.5 V$ ⁽⁴⁾				0.4	V
$V_{OUT(1)}$	Logical 1 Push-Pull Output Voltage	$I_{SOURCE} = 500 \mu A$, $V^+ \geq 2.7 V$			$0.8 \times V^+$		V
		$I_{SOURCE} = 800 \mu A$, $V^+ \geq 4.5 V$			$V^+ - 1.5$		V
V_{IH}	HYST Input Logical 1 Threshold Voltage				$0.8 \times V^+$		V
V_{IL}	HYST Input Logical 0 Threshold Voltage					$0.2 \times V^+$	V

- (3) The 1- μA limit is based on a testing limitation and does not reflect the actual performance of the part. Expect to see a doubling of the current for every 15°C increase in temperature. For example, the 1-nA typical current at 25°C would increase to 16 nA at 85°C.
- (4) Take care to include the effects of self heating when setting the maximum output load current. The power dissipation of the LM26 would increase by 1.28 mW when $I_{OUT} = 3.2 mA$ and $V_{OUT} = 0.4 V$. With a thermal resistance of 250°C/W, this power dissipation would cause an increase in the die temperature of about 0.32°C due to self heating. Self heating is not included in the trip point accuracy specification.

7.6 Typical Characteristics

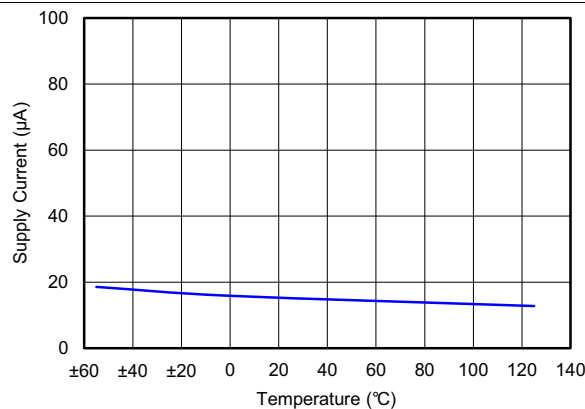

Figure 1. Power Supply Current Temperature Dependence

8 Detailed Description

8.1 Overview

The LM26 is a factory preset thermostat (temperature switch) that includes an integrated temperature sensor, reference voltage, DAC and comparator. The LM26 can be factory programmed to have a trip point anywhere in the range of -55°C to $+120^{\circ}\text{C}$. The output functionality can also be changed during the manufacturing process, as described in the functional block diagrams. Available options include:

- $\overline{\text{OS}}$: active low, open drain that indicates an over temperature shutdown event (most common)
- $\overline{\text{US}}$: active low, open-drain that indicates an under temperature shutdown event
- OS: active high, push-pull that indicates an over temperature shutdown event
- US: active high, push-pull that indicates an under temperature shutdown event

The internal temperature sensor is brought out on the V_{TEMP} pin and can be used to determine the temperature that the LM26 is reading by monitoring with an ADC. It has a negative temperature coefficient (NTC) of approximately $-10\text{mV}/^{\circ}\text{C}$. This pin also allows after assembly PCB testing (see section [After Assembly PCB Testing](#) for more details).

The comparator hysteresis is selectable by the state of the HYST. Two values are available 10°C or 2°C . Comparator hysteresis is essential, as it prevents comparator output chattering when the temperature is at the comparator threshold set point (REF as shown in the functional block diagrams). Once the comparator trips the hysteresis function changes the comparator threshold (REF) level such that the output remains locked in the active state. The threshold is changed by either 10°C or 2°C as programmed by the state of the HYST pin.

8.2 Functional Block Diagrams

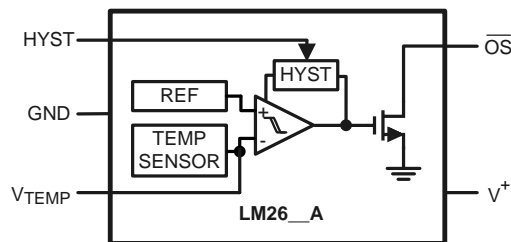

Figure 2. LM26__A Output Pin Block Diagram

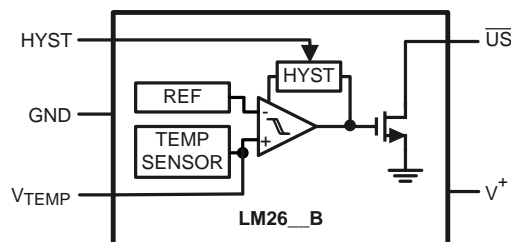

Figure 3. LM26__B Output Pin Block Diagram

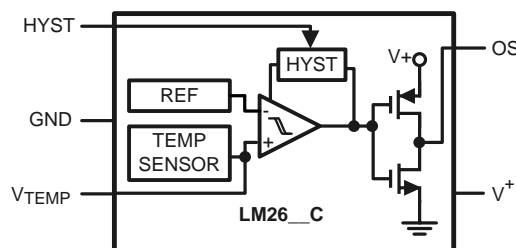
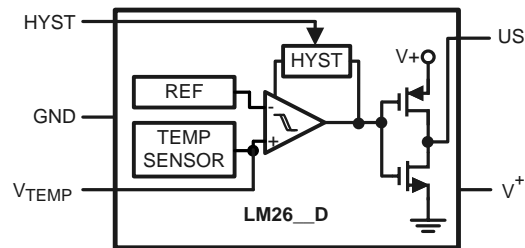

Figure 4. LM26__C Output Pin Block Diagram

Functional Block Diagrams (continued)

Figure 5. LM26-__D Output Pin Block Diagram
8.3 Feature Description
8.3.1 Hysteresis

The HYST pin level sets the comparator hysteresis. Setting the HYST pin to GND selects 10°C hysteresis, while setting it to V⁺ selects 2°C. A series resistor can be used for protection purposes. The input leakage current of the pin is less than 10 μA. The value of the resistor will depend on the value of V⁺ as well as the leakage current. For example with V⁺ = 3.3 V the input threshold level for V_{IH} = 0.8 × 3.3 V = 2.64 V, thus the voltage drop across the resistor should be less than 0.66 V. The 10-μA input leakage current requires the resistor value to be less than 66 kΩ.

8.3.2 V_{TEMP} Output

The V_{TEMP} output provides an output voltage that can be used to determine the temperature reading of the LM26. The temperature reading of the LM26 can be calculated using the equation:

$$V_o = (-3.47 \times 10^{-6} \times (T - 30)^2) + (1.082 \times 10^{-2} \times (T - 30)) + 1.8015 \text{ V} \quad (1)$$

or

$$T = -1525.04 + \sqrt{2.4182 \times 10^6 + \frac{1.8015 - V_{TEMP}}{3.479 \times 10^{-6}}} \quad (2)$$

The V_{TEMP} output has very weak drive capability (1-μA source, 40-μA sink). So care should be taken when attaching circuitry to this pin. Capacitive loading may cause the V_{TEMP} output to oscillate. Simply adding a resistor in series as shown in [Figure 6](#) and [Figure 7](#) will prevent oscillations from occurring. To determine the value of the resistor follow the guidelines given in [Table 1](#). The same value resistor will work for either placement of the resistor. If an additional capacitive load is placed directly on the LM26 output, rather than across C_{LOAD}, it should be at least a factor of 10 smaller than C_{LOAD}.

Table 1. Resistive Compensation for Capacitive Loading of V_{TEMP}

C _{LOAD}	R (Ω)
≤100pF	0
1nF	8200
10nF	3000
100nF	1000
≥1μF	430

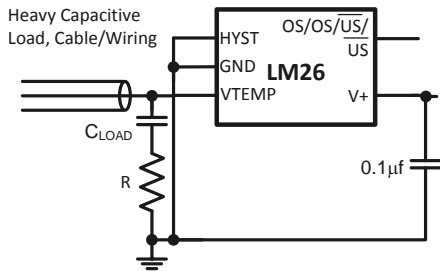

Figure 6. Resistor Placement for Capacitive-Loading Compensation of V_{TEMP} With R in Series With Capacitor

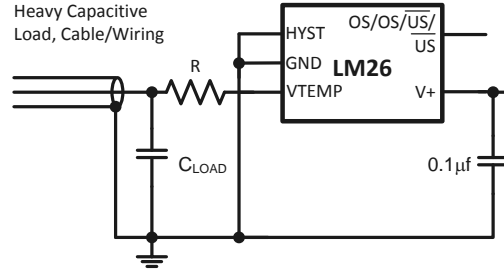

Figure 7. Resistor Placement for Capacitive-Loading Compensation of V_{TEMP} With R in Series With Signal Path

8.4 Device Functional Modes

The LM26 after factory programming has two functional modes one with 2°C Hysteresis and the other with 10°C hysteresis as programmed by the level of the HYST pin. Selection of the level will depend on the system noise and the temperature transition rate.

8.4.1 After Assembly PCB Testing

The LM26's V_{TEMP} output allows after-assembly PCB testing by following a simple test procedure. Simply measuring the V_{TEMP} output voltage will verify that the LM26 has been assembled properly and that its temperature sensing circuitry is functional. The V_{TEMP} output has very weak drive capability that can be overdriven by 1.5mA. Therefore, one can simply force the V_{TEMP} voltage to cause the digital output to change state, thereby verifying that the comparator and output circuitry function after assembly. Here is a sample test procedure that can be used to test the LM26CIM5-TPA which has an 85°C trip point.

1. Turn on V^+ and measure V_{TEMP} . Then calculate the temperature reading of the LM26 using the equation:

$$V_O = (-3.47 \times 10^{-6} \times (T - 30)^2) + (1.082 \times 10^{-2} \times (T - 30)) + 1.8015 \text{ V} \quad (3)$$

or

$$T = -1525.04 + \sqrt{2.4182 \times 10^6 + \frac{1.8015 - V_{TEMP}}{3.479 \times 10^{-6}}} \quad (4)$$

2. Verify that the temperature measured in step one is within ($\pm 3^\circ\text{C}$ + error of reference temperature sensor) of the ambient/board temperature. The ambient/board temperature (reference temperature) should be measured using an extremely accurate calibrated temperature sensor.
3.
 - (a) Observe that \overline{OS} is high.
 - (b) Drive V_{TEMP} to ground.
 - (c) Observe that \overline{OS} is now low.
 - (d) Release the V_{TEMP} pin.
 - (e) Observe that \overline{OS} is now high.
4.
 - (a) Observe that \overline{OS} is high.
 - (b) Drive V_{TEMP} voltage down gradually.
 - (c) When \overline{OS} goes low, note the V_{TEMP} voltage.
 - (d) $V_{TEMPTrig} = V_{TEMP}$ at \overline{OS} trigger (HIGH->LOW)
 - (e) Calculate Trig using [Equation 2](#).
5.
 - (a) Gradually raise V_{TEMP} until \overline{OS} goes HIGH. Note V_{TEMP} .
 - (b) Calculate T_{HYST} using [Equation 2](#).

9 Application and Implementation

NOTE

Information in the following applications sections is not part of the TI component specification, and TI does not warrant its accuracy or completeness. TI's customers are responsible for determining suitability of components for their purposes. Customers should validate and test their design implementation to confirm system functionality.

9.1 Application Information

The LM26 thermostat (temperature switch) can be used in applications such as microprocessor thermal management, appliances, fan control, industrial process control, power supplies for system protection, fan speed adjust or plain temperature monitoring.

9.2 Typical Application

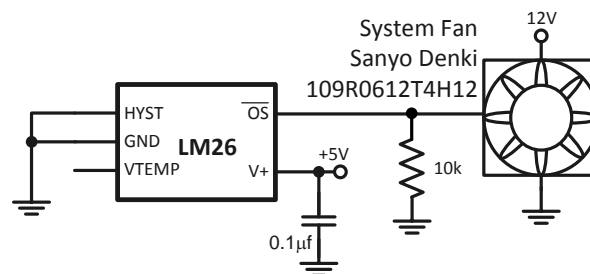

Figure 8. Two-Speed Fan Speed Control

9.2.1 Design Requirements

The requirement is to change speed for a fan to maximum at 45°C with an accuracy of

Table 2. Design Parameters

DESIGN PARAMETER	EXAMPLE VALUE
Min Fan Speed	1900 RPM
Max Fan Speed	3800 RPM
Temperature Threshold To Switch From Min Speed to Max Speed	45°C
Threshold accuracy	±3°C

9.2.2 Detailed Design Procedure

The design procedure is simple. A fan was selected that has the capability to be controlled by an external NTC thermistor. The recommended NTC thermistor adjusts the fan speed to maximum at 40°C. The LM26 meets the threshold accuracy requirements for temperature control of the fan speed and allows setting the max speed temperature threshold higher as required to 45°C. The resistance of the thermistor for the min fan speed is 6.8 kΩ. Since thermistors have a negative temperature coefficient (NTC), 10 kΩ was chosen to ensure that the fan is at min speed when the LM26 OS is off. When the OS output goes low at 45°C it simulates the low thermistor resistance at higher temperatures thus setting fan to max speed.

9.2.3 Application Curve

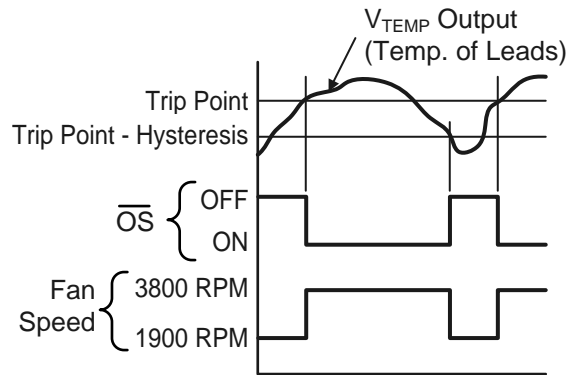

Figure 9. Temperature Effect on Fan Speed

9.3 System Examples

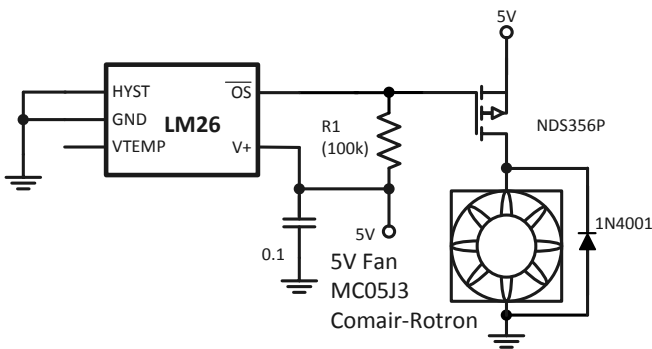

Figure 10. Fan High-Side Drive

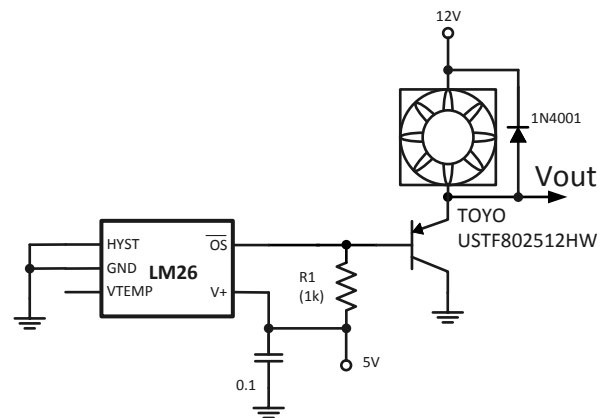

Figure 11. Fan Low-Side Drive

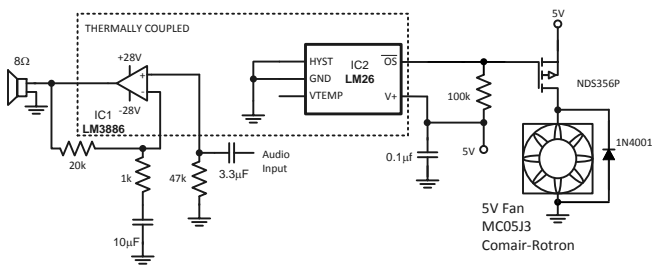

Figure 12. Audio Power Amplifier Thermal Protection

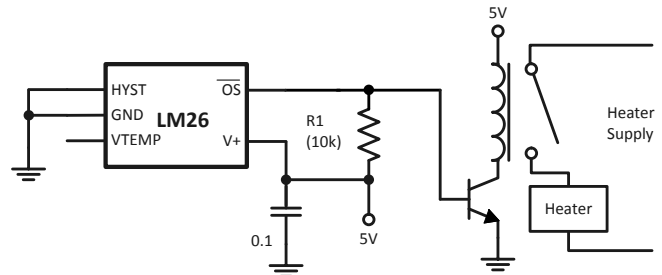

Figure 13. Simple Thermostat

10 Power Supply Recommendations

The LM26 has excellent power supply noise rejection. Listed below is a variety of signals used to test the LM26 power supply rejection. False triggering of the output was not observed when these signals were coupled into the V+ pin of the LM26.

- square wave 400 kHz, 1 Vp-p
- square wave 2 kHz, 200 mVp-p
- sine wave 100 Hz to 1 MHz, 200 mVp-p

Testing was done while maintaining the temperature of the LM26 one degree centigrade away from the trip point with the output not activated.

11 Layout

11.1 Layout Guidelines

The LM26 can be applied easily in the same way as other integrated-circuit temperature sensors. It can be glued or cemented to a surface. The temperature that the LM26 is sensing will be within about +0.06°C of the surface temperature to which the LM26's leads are attached to.

This presumes that the ambient air temperature is almost the same as the surface temperature; if the air temperature were much higher or lower than the surface temperature, the actual temperature measured would be at an intermediate temperature between the surface temperature and the air temperature.

To ensure good thermal conductivity, the backside of the LM26 die is directly attached to the GND pin (pin 2). The temperatures of the lands and traces to the other leads of the LM26 will also affect the temperature that is being sensed.

Alternatively, the LM26 can be mounted inside a sealed-end metal tube, and can then be dipped into a bath or screwed into a threaded hole in a tank. As with any IC, the LM26 and accompanying wiring and circuits must be kept insulated and dry, to avoid leakage and corrosion. This is especially true if the circuit may operate at cold temperatures where condensation can occur. Printed-circuit coatings and varnishes such as Humiseal and epoxy paints or dips are often used to ensure that moisture cannot corrode the LM26 or its connections.

11.2 Layout Example

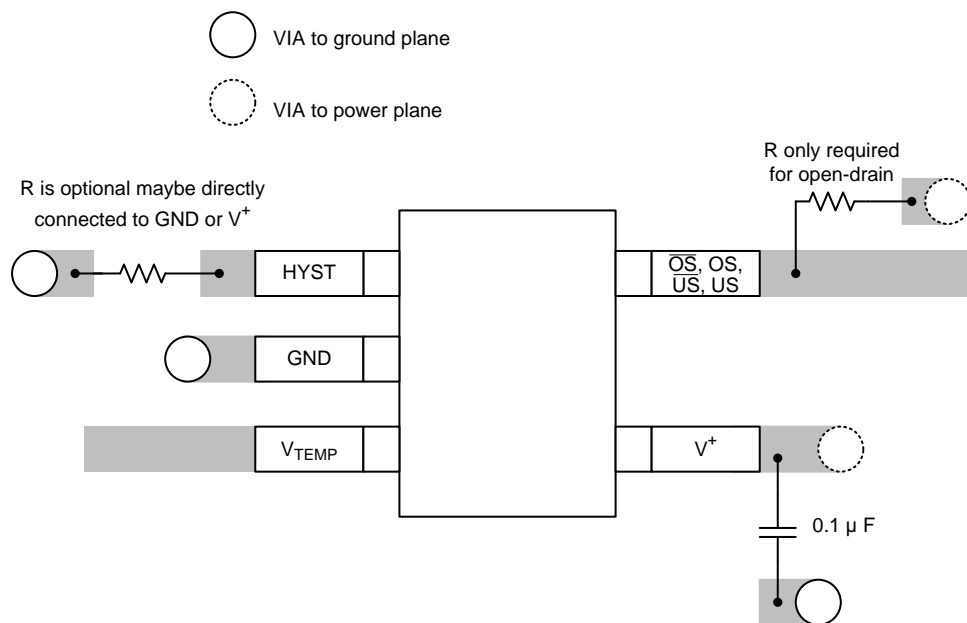

Figure 14. LM26 Typical Layout

11.3 Thermal Considerations

The junction to ambient thermal resistance ($R_{\theta JA}$) is the parameter used to calculate the rise of a part's junction temperature due to its power dissipation. For the LM26 the equation used to calculate the rise in the die junction temperature is as follows:

$$T_J = T_A + \Theta_{JA} (V^+ - V_{TEMP}) I_{L_TEMP} + V_{DO} I_{DO}$$

where

- T_A is the ambient temperature, V^+ is the power supply voltage
 - I_Q is the quiescent current, I_{L_TEMP} is the load current on the V_{TEMP} output
 - V_{DO} is the voltage on the digital output
 - and I_{DO} is the load current on the digital output
- (5)

Since the LM26's junction temperature is the actual temperature being measured, care should be taken to minimize the load current that the LM26 is required to drive.

[Table 3](#) summarizes the thermal resistance for different conditions and the rise in die temperature of the LM26 without any loading on V_{TEMP} and a 10-k Ω pullup resistor on an open-drain digital output with a 5.5-V power supply.

Table 3. Thermal resistance ($R_{\theta JA}$) and Temperature Rise Due to Self Heating ($T_J - T_A$)

	SOT-23 5 pin no heat sink	
	$R_{\theta JA}$ ($^{\circ}\text{C}/\text{W}$)	$T_J - T_A$ ($^{\circ}\text{C}$)
Still Air	250	0.11
Moving Air	TBD	TBD

11.4 Part Number Template

The series of digits labeled xyz in the part number LM26CIM-xyz, describe the set point value and the function of the output as follows:

The place holders xy describe the set point temperature as shown in the following table.

x (10x)	y (1x)	Temperature (°C)
A	-	-5
B	-	-4
C	-	-3
D	-	-2
E	-	-1
F	-	-0
H	H	0
J	J	1
K	K	2
L	L	3
N	N	4
P	P	5
R	R	6
S	S	7
T	T	8
V	V	9
X	-	10
Y	-	11
Z	-	12

The value of z describes the assignment/function of the output as shown in the following table:

Active-Low/High	Open-Drain/ Push-Pull	\overline{OS}/US	Value of z	Digital Output Function
0	0	0	A	Active-Low, Open-Drain, \overline{OS} output
0	0	1	B	Active-Low, Open-Drain, \overline{US} output
1	1	0	C	Active-High, Push-Pull, OS output
1	1	1	D	Active-High, Push-Pull, US output

For example:

- the part number LM26CIM5-TPA has $T_{OS} = 85^{\circ}\text{C}$, and programmed as an active-low open-drain overtemperature shutdown output.
- the part number LM26CIM5-FPD has $T_{US} = -5^{\circ}\text{C}$, and programmed as an active-high, push-pull undertemperature shutdown output.

Active-high open-drain and active-low push-pull options are available, please contact Texas Instruments for more information.

12 Device and Documentation Support

12.1 Community Resources

The following links connect to TI community resources. Linked contents are provided "AS IS" by the respective contributors. They do not constitute TI specifications and do not necessarily reflect TI's views; see TI's [Terms of Use](#).

TI E2E™ Online Community *TI's Engineer-to-Engineer (E2E) Community*. Created to foster collaboration among engineers. At e2e.ti.com, you can ask questions, share knowledge, explore ideas and help solve problems with fellow engineers.

Design Support *TI's Design Support* Quickly find helpful E2E forums along with design support tools and contact information for technical support.

12.2 Trademarks

E2E is a trademark of Texas Instruments.
All other trademarks are the property of their respective owners.

12.3 Electrostatic Discharge Caution



These devices have limited built-in ESD protection. The leads should be shorted together or the device placed in conductive foam during storage or handling to prevent electrostatic damage to the MOS gates.

12.4 Glossary

[SLYZ022](#) — *TI Glossary*.

This glossary lists and explains terms, acronyms, and definitions.

13 Mechanical, Packaging, and Orderable Information

The following pages include mechanical, packaging, and orderable information. This information is the most current data available for the designated devices. This data is subject to change without notice and revision of this document. For browser-based versions of this data sheet, refer to the left-hand navigation.

PACKAGING INFORMATION

Orderable Device	Status (1)	Package Type	Package Drawing	Pins	Package Qty	Eco Plan (2)	Lead/Ball Finish (6)	MSL Peak Temp (3)	Op Temp (°C)	Device Marking (4/5)	Samples
LM26CIM5-BPB/NOPB	ACTIVE	SOT-23	DBV	5	1000	Green (RoHS & no Sb/Br)	CU SN	Level-1-260C-UNLIM		TBPB	Samples
LM26CIM5-DPB/NOPB	ACTIVE	SOT-23	DBV	5	1000	Green (RoHS & no Sb/Br)	CU SN	Level-1-260C-UNLIM	-55 to 125	TDPB	Samples
LM26CIM5-HHD/NOPB	ACTIVE	SOT-23	DBV	5	1000	Green (RoHS & no Sb/Br)	CU SN	Level-1-260C-UNLIM	-55 to 125	THHD	Samples
LM26CIM5-NPA/NOPB	ACTIVE	SOT-23	DBV	5	1000	Green (RoHS & no Sb/Br)	CU SN	Level-1-260C-UNLIM	-55 to 125	TNPA	Samples
LM26CIM5-PHA/NOPB	ACTIVE	SOT-23	DBV	5	1000	Green (RoHS & no Sb/Br)	CU SN	Level-1-260C-UNLIM	-55 to 125	TPHA	Samples
LM26CIM5-RPA	NRND	SOT-23	DBV	5	1000	TBD	Call TI	Call TI	-55 to 125	TRPA	
LM26CIM5-RPA/NOPB	ACTIVE	SOT-23	DBV	5	1000	Green (RoHS & no Sb/Br)	CU SN	Level-1-260C-UNLIM	-55 to 125	TRPA	Samples
LM26CIM5-SHA/NOPB	ACTIVE	SOT-23	DBV	5	1000	Green (RoHS & no Sb/Br)	CU SN	Level-1-260C-UNLIM	-55 to 125	TSHA	Samples
LM26CIM5-SPA/NOPB	ACTIVE	SOT-23	DBV	5	1000	Green (RoHS & no Sb/Br)	CU SN	Level-1-260C-UNLIM	-55 to 125	TSPA	Samples
LM26CIM5-TPA/NOPB	ACTIVE	SOT-23	DBV	5	1000	Green (RoHS & no Sb/Br)	CU SN	Level-1-260C-UNLIM	-55 to 125	TTPA	Samples
LM26CIM5-VHA/NOPB	ACTIVE	SOT-23	DBV	5	1000	Green (RoHS & no Sb/Br)	CU SN	Level-1-260C-UNLIM	-55 to 125	TVHA	Samples
LM26CIM5-VPA/NOPB	ACTIVE	SOT-23	DBV	5	1000	Green (RoHS & no Sb/Br)	CU SN	Level-1-260C-UNLIM	-55 to 125	TVPA	Samples
LM26CIM5-XHA/NOPB	ACTIVE	SOT-23	DBV	5	1000	Green (RoHS & no Sb/Br)	CU SN	Level-1-260C-UNLIM	-55 to 125	TXHA	Samples
LM26CIM5-XPA/NOPB	ACTIVE	SOT-23	DBV	5	1000	Green (RoHS & no Sb/Br)	CU SN	Level-1-260C-UNLIM	-55 to 125	TXPA	Samples
LM26CIM5-YHA/NOPB	ACTIVE	SOT-23	DBV	5	1000	Green (RoHS & no Sb/Br)	CU SN	Level-1-260C-UNLIM	-55 to 125	TYHA	Samples
LM26CIM5-YPA/NOPB	ACTIVE	SOT-23	DBV	5	1000	Green (RoHS & no Sb/Br)	CU SN	Level-1-260C-UNLIM	-55 to 125	TYPA	Samples
LM26CIM5-ZHA	NRND	SOT-23	DBV	5	1000	TBD	Call TI	Call TI	-55 to 125	TZHA	
LM26CIM5-ZHA/NOPB	ACTIVE	SOT-23	DBV	5	1000	Green (RoHS & no Sb/Br)	CU SN	Level-1-260C-UNLIM	-55 to 125	TZHA	Samples

Orderable Device	Status (1)	Package Type	Package Drawing	Pins	Package Qty	Eco Plan (2)	Lead/Ball Finish (6)	MSL Peak Temp (3)	Op Temp (°C)	Device Marking (4/5)	Samples
LM26CIM5X-DPB/NOPB	ACTIVE	SOT-23	DBV	5	3000	Green (RoHS & no Sb/Br)	CU SN	Level-1-260C-UNLIM	-55 to 125	TDPB	Samples
LM26CIM5X-HHD	NRND	SOT-23	DBV	5	3000	TBD	Call TI	Call TI	-55 to 125	THHD	
LM26CIM5X-HHD/NOPB	ACTIVE	SOT-23	DBV	5	3000	Green (RoHS & no Sb/Br)	CU SN	Level-1-260C-UNLIM	-55 to 125	THHD	Samples
LM26CIM5X-NPA/NOPB	ACTIVE	SOT-23	DBV	5	3000	Green (RoHS & no Sb/Br)	CU SN	Level-1-260C-UNLIM	-55 to 125	TNPA	Samples
LM26CIM5X-PHA/NOPB	ACTIVE	SOT-23	DBV	5	3000	Green (RoHS & no Sb/Br)	CU SN	Level-1-260C-UNLIM	-55 to 125	TPHA	Samples
LM26CIM5X-SPA/NOPB	ACTIVE	SOT-23	DBV	5	3000	Green (RoHS & no Sb/Br)	CU SN	Level-1-260C-UNLIM	-55 to 125	TSPA	Samples
LM26CIM5X-TPA/NOPB	ACTIVE	SOT-23	DBV	5	3000	Green (RoHS & no Sb/Br)	CU SN	Level-1-260C-UNLIM	-55 to 125	TTPA	Samples
LM26CIM5X-VHA/NOPB	ACTIVE	SOT-23	DBV	5	3000	Green (RoHS & no Sb/Br)	CU SN	Level-1-260C-UNLIM	-55 to 125	TVHA	Samples
LM26CIM5X-VPA/NOPB	ACTIVE	SOT-23	DBV	5	3000	Green (RoHS & no Sb/Br)	CU SN	Level-1-260C-UNLIM	-55 to 125	TVPA	Samples
LM26CIM5X-XHA/NOPB	ACTIVE	SOT-23	DBV	5	3000	Green (RoHS & no Sb/Br)	CU SN	Level-1-260C-UNLIM	-55 to 125	TXHA	Samples
LM26CIM5X-XPA/NOPB	ACTIVE	SOT-23	DBV	5	3000	Green (RoHS & no Sb/Br)	CU SN	Level-1-260C-UNLIM	-55 to 125	TXPA	Samples
LM26CIM5X-YHA/NOPB	ACTIVE	SOT-23	DBV	5	3000	Green (RoHS & no Sb/Br)	CU SN	Level-1-260C-UNLIM	-55 to 125	TYHA	Samples
LM26CIM5X-YPA/NOPB	ACTIVE	SOT-23	DBV	5	3000	Green (RoHS & no Sb/Br)	CU SN	Level-1-260C-UNLIM	-55 to 125	TYPA	Samples
LM26CIM5X-ZHA/NOPB	ACTIVE	SOT-23	DBV	5	3000	Green (RoHS & no Sb/Br)	CU SN	Level-1-260C-UNLIM	-55 to 125	TZHA	Samples

(1) The marketing status values are defined as follows:

ACTIVE: Product device recommended for new designs.

LIFEBUY: TI has announced that the device will be discontinued, and a lifetime-buy period is in effect.

NRND: Not recommended for new designs. Device is in production to support existing customers, but TI does not recommend using this part in a new design.

PREVIEW: Device has been announced but is not in production. Samples may or may not be available.

OBSELETE: TI has discontinued the production of the device.

(2) **RoHS:** TI defines "RoHS" to mean semiconductor products that are compliant with the current EU RoHS requirements for all 10 RoHS substances, including the requirement that RoHS substance do not exceed 0.1% by weight in homogeneous materials. Where designed to be soldered at high temperatures, "RoHS" products are suitable for use in specified lead-free processes. TI may reference these types of products as "Pb-Free".

RoHS Exempt: TI defines "RoHS Exempt" to mean products that contain lead but are compliant with EU RoHS pursuant to a specific EU RoHS exemption.

Green: TI defines "Green" to mean the content of Chlorine (Cl) and Bromine (Br) based flame retardants meet JS709B low halogen requirements of ≤ 1000 ppm threshold. Antimony trioxide based flame retardants must also meet the ≤ 1000 ppm threshold requirement.

(3) MSL, Peak Temp. - The Moisture Sensitivity Level rating according to the JEDEC industry standard classifications, and peak solder temperature.

(4) There may be additional marking, which relates to the logo, the lot trace code information, or the environmental category on the device.

(5) Multiple Device Markings will be inside parentheses. Only one Device Marking contained in parentheses and separated by a "~" will appear on a device. If a line is indented then it is a continuation of the previous line and the two combined represent the entire Device Marking for that device.

(6) Lead/Ball Finish - Orderable Devices may have multiple material finish options. Finish options are separated by a vertical ruled line. Lead/Ball Finish values may wrap to two lines if the finish value exceeds the maximum column width.

Important Information and Disclaimer: The information provided on this page represents TI's knowledge and belief as of the date that it is provided. TI bases its knowledge and belief on information provided by third parties, and makes no representation or warranty as to the accuracy of such information. Efforts are underway to better integrate information from third parties. TI has taken and continues to take reasonable steps to provide representative and accurate information but may not have conducted destructive testing or chemical analysis on incoming materials and chemicals. TI and TI suppliers consider certain information to be proprietary, and thus CAS numbers and other limited information may not be available for release.

In no event shall TI's liability arising out of such information exceed the total purchase price of the TI part(s) at issue in this document sold by TI to Customer on an annual basis.

TAPE AND REEL INFORMATION

QUADRANT ASSIGNMENTS FOR PIN 1 ORIENTATION IN TAPE

*All dimensions are nominal

Device	Package Type	Package Drawing	Pins	SPQ	Reel Diameter (mm)	Reel Width W1 (mm)	A0 (mm)	B0 (mm)	K0 (mm)	P1 (mm)	W (mm)	Pin1 Quadrant
LM26CIM5-BPB/NOPB	SOT-23	DBV	5	1000	178.0	8.4	3.2	3.2	1.4	4.0	8.0	Q3
LM26CIM5-DPB/NOPB	SOT-23	DBV	5	1000	178.0	8.4	3.2	3.2	1.4	4.0	8.0	Q3
LM26CIM5-HHD/NOPB	SOT-23	DBV	5	1000	178.0	8.4	3.2	3.2	1.4	4.0	8.0	Q3
LM26CIM5-NPA/NOPB	SOT-23	DBV	5	1000	178.0	8.4	3.2	3.2	1.4	4.0	8.0	Q3
LM26CIM5-PHA/NOPB	SOT-23	DBV	5	1000	178.0	8.4	3.2	3.2	1.4	4.0	8.0	Q3
LM26CIM5-RPA	SOT-23	DBV	5	1000	178.0	8.4	3.2	3.2	1.4	4.0	8.0	Q3
LM26CIM5-RPA/NOPB	SOT-23	DBV	5	1000	178.0	8.4	3.2	3.2	1.4	4.0	8.0	Q3
LM26CIM5-SHA/NOPB	SOT-23	DBV	5	1000	178.0	8.4	3.2	3.2	1.4	4.0	8.0	Q3
LM26CIM5-SPA/NOPB	SOT-23	DBV	5	1000	178.0	8.4	3.2	3.2	1.4	4.0	8.0	Q3
LM26CIM5-TPA/NOPB	SOT-23	DBV	5	1000	178.0	8.4	3.2	3.2	1.4	4.0	8.0	Q3
LM26CIM5-VHA/NOPB	SOT-23	DBV	5	1000	178.0	8.4	3.2	3.2	1.4	4.0	8.0	Q3
LM26CIM5-VPA/NOPB	SOT-23	DBV	5	1000	178.0	8.4	3.2	3.2	1.4	4.0	8.0	Q3
LM26CIM5-XHA/NOPB	SOT-23	DBV	5	1000	178.0	8.4	3.2	3.2	1.4	4.0	8.0	Q3
LM26CIM5-XPA/NOPB	SOT-23	DBV	5	1000	178.0	8.4	3.2	3.2	1.4	4.0	8.0	Q3
LM26CIM5-YHA/NOPB	SOT-23	DBV	5	1000	178.0	8.4	3.2	3.2	1.4	4.0	8.0	Q3
LM26CIM5-YPA/NOPB	SOT-23	DBV	5	1000	178.0	8.4	3.2	3.2	1.4	4.0	8.0	Q3
LM26CIM5-ZHA	SOT-23	DBV	5	1000	178.0	8.4	3.2	3.2	1.4	4.0	8.0	Q3
LM26CIM5-ZHA/NOPB	SOT-23	DBV	5	1000	178.0	8.4	3.2	3.2	1.4	4.0	8.0	Q3

Device	Package Type	Package Drawing	Pins	SPQ	Reel Diameter (mm)	Reel Width W1 (mm)	A0 (mm)	B0 (mm)	K0 (mm)	P1 (mm)	W (mm)	Pin1 Quadrant
LM26CIM5X-DPB/NOPB	SOT-23	DBV	5	3000	178.0	8.4	3.2	3.2	1.4	4.0	8.0	Q3
LM26CIM5X-HHD	SOT-23	DBV	5	3000	178.0	8.4	3.2	3.2	1.4	4.0	8.0	Q3
LM26CIM5X-HHD/NOPB	SOT-23	DBV	5	3000	178.0	8.4	3.2	3.2	1.4	4.0	8.0	Q3
LM26CIM5X-NPA/NOPB	SOT-23	DBV	5	3000	178.0	8.4	3.2	3.2	1.4	4.0	8.0	Q3
LM26CIM5X-PHA/NOPB	SOT-23	DBV	5	3000	178.0	8.4	3.2	3.2	1.4	4.0	8.0	Q3
LM26CIM5X-SPA/NOPB	SOT-23	DBV	5	3000	178.0	8.4	3.2	3.2	1.4	4.0	8.0	Q3
LM26CIM5X-TPA/NOPB	SOT-23	DBV	5	3000	178.0	8.4	3.2	3.2	1.4	4.0	8.0	Q3
LM26CIM5X-VHA/NOPB	SOT-23	DBV	5	3000	178.0	8.4	3.2	3.2	1.4	4.0	8.0	Q3
LM26CIM5X-VPA/NOPB	SOT-23	DBV	5	3000	178.0	8.4	3.2	3.2	1.4	4.0	8.0	Q3
LM26CIM5X-XHA/NOPB	SOT-23	DBV	5	3000	178.0	8.4	3.2	3.2	1.4	4.0	8.0	Q3
LM26CIM5X-XPA/NOPB	SOT-23	DBV	5	3000	178.0	8.4	3.2	3.2	1.4	4.0	8.0	Q3
LM26CIM5X-YHA/NOPB	SOT-23	DBV	5	3000	178.0	8.4	3.2	3.2	1.4	4.0	8.0	Q3
LM26CIM5X-YPA/NOPB	SOT-23	DBV	5	3000	178.0	8.4	3.2	3.2	1.4	4.0	8.0	Q3
LM26CIM5X-ZHA/NOPB	SOT-23	DBV	5	3000	178.0	8.4	3.2	3.2	1.4	4.0	8.0	Q3

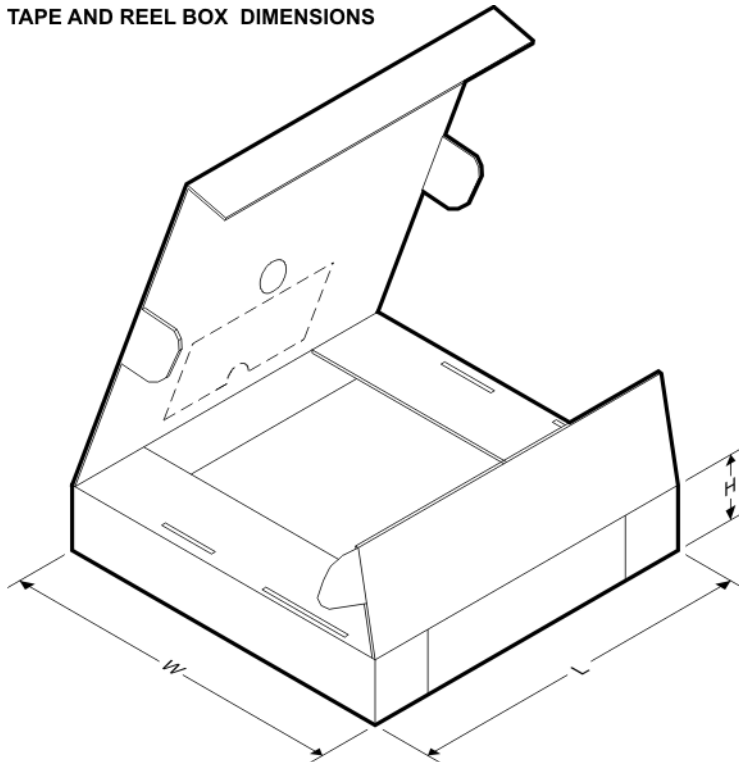
TAPE AND REEL BOX DIMENSIONS

*All dimensions are nominal

Device	Package Type	Package Drawing	Pins	SPQ	Length (mm)	Width (mm)	Height (mm)
LM26CIM5-BPB/NOPB	SOT-23	DBV	5	1000	210.0	185.0	35.0
LM26CIM5-DPB/NOPB	SOT-23	DBV	5	1000	210.0	185.0	35.0
LM26CIM5-HHD/NOPB	SOT-23	DBV	5	1000	210.0	185.0	35.0

Device	Package Type	Package Drawing	Pins	SPQ	Length (mm)	Width (mm)	Height (mm)
LM26CIM5-NPA/NOPB	SOT-23	DBV	5	1000	210.0	185.0	35.0
LM26CIM5-PHA/NOPB	SOT-23	DBV	5	1000	210.0	185.0	35.0
LM26CIM5-RPA	SOT-23	DBV	5	1000	210.0	185.0	35.0
LM26CIM5-RPA/NOPB	SOT-23	DBV	5	1000	210.0	185.0	35.0
LM26CIM5-SHA/NOPB	SOT-23	DBV	5	1000	210.0	185.0	35.0
LM26CIM5-SPA/NOPB	SOT-23	DBV	5	1000	210.0	185.0	35.0
LM26CIM5-TPA/NOPB	SOT-23	DBV	5	1000	210.0	185.0	35.0
LM26CIM5-VHA/NOPB	SOT-23	DBV	5	1000	210.0	185.0	35.0
LM26CIM5-VPA/NOPB	SOT-23	DBV	5	1000	210.0	185.0	35.0
LM26CIM5-XHA/NOPB	SOT-23	DBV	5	1000	210.0	185.0	35.0
LM26CIM5-XPA/NOPB	SOT-23	DBV	5	1000	210.0	185.0	35.0
LM26CIM5-YHA/NOPB	SOT-23	DBV	5	1000	210.0	185.0	35.0
LM26CIM5-YPA/NOPB	SOT-23	DBV	5	1000	210.0	185.0	35.0
LM26CIM5-ZHA	SOT-23	DBV	5	1000	210.0	185.0	35.0
LM26CIM5-ZHA/NOPB	SOT-23	DBV	5	1000	210.0	185.0	35.0
LM26CIM5X-DPB/NOPB	SOT-23	DBV	5	3000	210.0	185.0	35.0
LM26CIM5X-HHD	SOT-23	DBV	5	3000	210.0	185.0	35.0
LM26CIM5X-HHD/NOPB	SOT-23	DBV	5	3000	210.0	185.0	35.0
LM26CIM5X-NPA/NOPB	SOT-23	DBV	5	3000	210.0	185.0	35.0
LM26CIM5X-PHA/NOPB	SOT-23	DBV	5	3000	210.0	185.0	35.0
LM26CIM5X-SPA/NOPB	SOT-23	DBV	5	3000	210.0	185.0	35.0
LM26CIM5X-TPA/NOPB	SOT-23	DBV	5	3000	210.0	185.0	35.0
LM26CIM5X-VHA/NOPB	SOT-23	DBV	5	3000	210.0	185.0	35.0
LM26CIM5X-VPA/NOPB	SOT-23	DBV	5	3000	210.0	185.0	35.0
LM26CIM5X-XHA/NOPB	SOT-23	DBV	5	3000	210.0	185.0	35.0
LM26CIM5X-XPA/NOPB	SOT-23	DBV	5	3000	210.0	185.0	35.0
LM26CIM5X-YHA/NOPB	SOT-23	DBV	5	3000	210.0	185.0	35.0
LM26CIM5X-YPA/NOPB	SOT-23	DBV	5	3000	210.0	185.0	35.0
LM26CIM5X-ZHA/NOPB	SOT-23	DBV	5	3000	210.0	185.0	35.0

GENERIC PACKAGE VIEW

DBV 5

SOT-23 - 1.45 mm max height

SMALL OUTLINE TRANSISTOR



Images above are just a representation of the package family, actual package may vary.
Refer to the product data sheet for package details.

4073253/P

DBV0005A



PACKAGE OUTLINE

SOT-23 - 1.45 mm max height

SMALL OUTLINE TRANSISTOR



4214839/C 04/2017

NOTES:

1. All linear dimensions are in millimeters. Any dimensions in parenthesis are for reference only. Dimensioning and tolerancing per ASME Y14.5M.
2. This drawing is subject to change without notice.
3. Reference JEDEC MO-178.

EXAMPLE BOARD LAYOUT

DBV0005A

SOT-23 - 1.45 mm max height

SMALL OUTLINE TRANSISTOR



LAND PATTERN EXAMPLE
EXPOSED METAL SHOWN
SCALE:15X

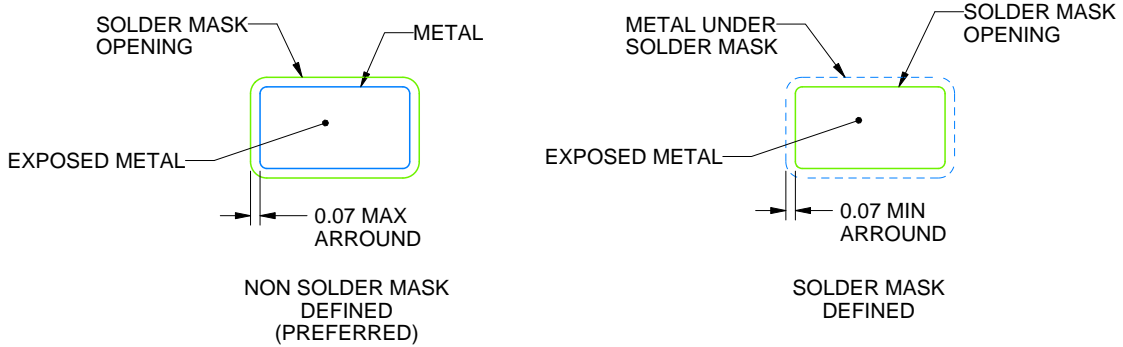

SOLDER MASK DETAILS

4214839/C 04/2017

NOTES: (continued)

- 4. Publication IPC-7351 may have alternate designs.
- 5. Solder mask tolerances between and around signal pads can vary based on board fabrication site.

EXAMPLE STENCIL DESIGN

DBV0005A

SOT-23 - 1.45 mm max height

SMALL OUTLINE TRANSISTOR



SOLDER PASTE EXAMPLE
BASED ON 0.125 mm THICK STENCIL
SCALE:15X

4214839/C 04/2017

NOTES: (continued)

6. Laser cutting apertures with trapezoidal walls and rounded corners may offer better paste release. IPC-7525 may have alternate design recommendations.
7. Board assembly site may have different recommendations for stencil design.

IMPORTANT NOTICE

Texas Instruments Incorporated (TI) reserves the right to make corrections, enhancements, improvements and other changes to its semiconductor products and services per JESD46, latest issue, and to discontinue any product or service per JESD48, latest issue. Buyers should obtain the latest relevant information before placing orders and should verify that such information is current and complete.

TI's published terms of sale for semiconductor products (<http://www.ti.com/sc/docs/stdterms.htm>) apply to the sale of packaged integrated circuit products that TI has qualified and released to market. Additional terms may apply to the use or sale of other types of TI products and services.

Reproduction of significant portions of TI information in TI data sheets is permissible only if reproduction is without alteration and is accompanied by all associated warranties, conditions, limitations, and notices. TI is not responsible or liable for such reproduced documentation. Information of third parties may be subject to additional restrictions. Resale of TI products or services with statements different from or beyond the parameters stated by TI for that product or service voids all express and any implied warranties for the associated TI product or service and is an unfair and deceptive business practice. TI is not responsible or liable for any such statements.

Buyers and others who are developing systems that incorporate TI products (collectively, "Designers") understand and agree that Designers remain responsible for using their independent analysis, evaluation and judgment in designing their applications and that Designers have full and exclusive responsibility to assure the safety of Designers' applications and compliance of their applications (and of all TI products used in or for Designers' applications) with all applicable regulations, laws and other applicable requirements. Designer represents that, with respect to their applications, Designer has all the necessary expertise to create and implement safeguards that (1) anticipate dangerous consequences of failures, (2) monitor failures and their consequences, and (3) lessen the likelihood of failures that might cause harm and take appropriate actions. Designer agrees that prior to using or distributing any applications that include TI products, Designer will thoroughly test such applications and the functionality of such TI products as used in such applications.

TI's provision of technical, application or other design advice, quality characterization, reliability data or other services or information, including, but not limited to, reference designs and materials relating to evaluation modules, (collectively, "TI Resources") are intended to assist designers who are developing applications that incorporate TI products; by downloading, accessing or using TI Resources in any way, Designer (individually or, if Designer is acting on behalf of a company, Designer's company) agrees to use any particular TI Resource solely for this purpose and subject to the terms of this Notice.

TI's provision of TI Resources does not expand or otherwise alter TI's applicable published warranties or warranty disclaimers for TI products, and no additional obligations or liabilities arise from TI providing such TI Resources. TI reserves the right to make corrections, enhancements, improvements and other changes to its TI Resources. TI has not conducted any testing other than that specifically described in the published documentation for a particular TI Resource.

Designer is authorized to use, copy and modify any individual TI Resource only in connection with the development of applications that include the TI product(s) identified in such TI Resource. NO OTHER LICENSE, EXPRESS OR IMPLIED, BY ESTOPPEL OR OTHERWISE TO ANY OTHER TI INTELLECTUAL PROPERTY RIGHT, AND NO LICENSE TO ANY TECHNOLOGY OR INTELLECTUAL PROPERTY RIGHT OF TI OR ANY THIRD PARTY IS GRANTED HEREIN, including but not limited to any patent right, copyright, mask work right, or other intellectual property right relating to any combination, machine, or process in which TI products or services are used. Information regarding or referencing third-party products or services does not constitute a license to use such products or services, or a warranty or endorsement thereof. Use of TI Resources may require a license from a third party under the patents or other intellectual property of the third party, or a license from TI under the patents or other intellectual property of TI.

TI RESOURCES ARE PROVIDED "AS IS" AND WITH ALL FAULTS. TI DISCLAIMS ALL OTHER WARRANTIES OR REPRESENTATIONS, EXPRESS OR IMPLIED, REGARDING RESOURCES OR USE THEREOF, INCLUDING BUT NOT LIMITED TO ACCURACY OR COMPLETENESS, TITLE, ANY EPIDEMIC FAILURE WARRANTY AND ANY IMPLIED WARRANTIES OF MERCHANTABILITY, FITNESS FOR A PARTICULAR PURPOSE, AND NON-INFRINGEMENT OF ANY THIRD PARTY INTELLECTUAL PROPERTY RIGHTS. TI SHALL NOT BE LIABLE FOR AND SHALL NOT DEFEND OR INDEMNIFY DESIGNER AGAINST ANY CLAIM, INCLUDING BUT NOT LIMITED TO ANY INFRINGEMENT CLAIM THAT RELATES TO OR IS BASED ON ANY COMBINATION OF PRODUCTS EVEN IF DESCRIBED IN TI RESOURCES OR OTHERWISE. IN NO EVENT SHALL TI BE LIABLE FOR ANY ACTUAL, DIRECT, SPECIAL, COLLATERAL, INDIRECT, PUNITIVE, INCIDENTAL, CONSEQUENTIAL OR EXEMPLARY DAMAGES IN CONNECTION WITH OR ARISING OUT OF TI RESOURCES OR USE THEREOF, AND REGARDLESS OF WHETHER TI HAS BEEN ADVISED OF THE POSSIBILITY OF SUCH DAMAGES.

Unless TI has explicitly designated an individual product as meeting the requirements of a particular industry standard (e.g., ISO/TS 16949 and ISO 26262), TI is not responsible for any failure to meet such industry standard requirements.

Where TI specifically promotes products as facilitating functional safety or as compliant with industry functional safety standards, such products are intended to help enable customers to design and create their own applications that meet applicable functional safety standards and requirements. Using products in an application does not by itself establish any safety features in the application. Designers must ensure compliance with safety-related requirements and standards applicable to their applications. Designer may not use any TI products in life-critical medical equipment unless authorized officers of the parties have executed a special contract specifically governing such use. Life-critical medical equipment is medical equipment where failure of such equipment would cause serious bodily injury or death (e.g., life support, pacemakers, defibrillators, heart pumps, neurostimulators, and implantables). Such equipment includes, without limitation, all medical devices identified by the U.S. Food and Drug Administration as Class III devices and equivalent classifications outside the U.S.

TI may expressly designate certain products as completing a particular qualification (e.g., Q100, Military Grade, or Enhanced Product). Designers agree that it has the necessary expertise to select the product with the appropriate qualification designation for their applications and that proper product selection is at Designers' own risk. Designers are solely responsible for compliance with all legal and regulatory requirements in connection with such selection.

Designer will fully indemnify TI and its representatives against any damages, costs, losses, and/or liabilities arising out of Designer's non-compliance with the terms and provisions of this Notice.